

Table of Contents

1	Introduction	3
1.1	What is the Vivo 65?	3
1.2	Intended Use	4
1.3	Indications for Use	5
1.4	Contraindications	5
1.5	About this Manual	6
2	Safety Information	8
2.1	General User Precautions	8
2.2	Electrical Safety	11
2.3	Environmental Conditions	12
2.4	Usage of Patient Circuit	14
2.5	Usage of Filters	17
2.6	Humidification	18
2.7	Cleaning and Maintenance	19
2.8	Usage of Oxygen	20
3	Product Description	22
3.1	Main Components	22
3.2	The Vivo 65's Front Panel	24
3.3	The Vivo 65's Side Panels	25
3.4	Equipment Designation and Safety Labels	28
4	Preparing the Vivo 65 for Use	31
4.1	Checking the Vivo 65 before First Use	31
4.2	Placing the Vivo 65	32
4.3	Connecting the Vivo 65 to AC Power	34
4.4	Connecting the Patient Circuit	35
4.5	Inspecting the Vivo 65 before Use	40
4.6	Performing the Pre-use Test	41
5	How to Use the Vivo 65	43
5.1	Turning the Vivo 65 On and Off	43
5.2	Using the Menu	45
5.3	Monitored Values in the Vivo 65	54
5.4	Functions and Parameters in the Vivo 65	60
5.5	Modes in the Vivo 65	82
5.6	Transferring Data between the Vivo 65 and a PC	91
5.7	Using Batteries	92
5.8	Using Accessories	101
6	Alarms	111
6.1	Alarm Function	111
6.2	Operator's Position	113
6.3	Physiological Alarms	114
6.4	Technical Alarms	142
6.5	Alarm Test	168

7	Cleaning and Maintenance	169
7.1	Cleaning the Vivo 65	170
7.2	Cleaning and Replacing the Patient Air Filters.....	172
7.3	Change of Patient	173
7.4	Regular Maintenance Control	174
7.5	Service and Repair.....	174
7.6	Storage	174
7.7	Disposal	175
8	Technical Specifications	176
8.1	System Description	176
8.2	Data Parameters	181
8.3	Emission and Immunity Declaration.....	196
8.4	Default Settings.....	203
9	Accessories.....	207
9.1	Breas Accessories List.....	207
10	Patient Settings	213
11	FAA Compliance	214
12	Index	220

1 Introduction



WARNING!

Vivo 65 must only be used:

- For the intended treatment in accordance with this operating manual and with the instructions given by the responsible clinical personnel.
- In accordance with the operating conditions specified in this operating manual.
- In original and unmodified shape and only with accessories specified or approved by Breas Medical AB.

Every other use may lead to risk of personal injury!



CAUTION!

Read this operating manual thoroughly so that you completely understand how the Vivo 65 is operated and maintained before operating the device to ensure correct usage, maximum performance and serviceability. Non-professional caregivers (e.g., family members) should consult the medical equipment provider's respiratory therapist if they have any questions about the function, proper use, operation, service or maintenance of the Vivo 65.



Caution: U.S. Federal law restricts this device to sale by or on order of a physician.

1.1 What is the Vivo 65?

The Vivo 65 is a pressure and volume ventilator capable of delivering continuous or intermittent ventilatory support for patients who require invasive or non-invasive mechanical ventilation.

The Vivo 65 can be operated in 13 different combinations of ventilation and breath modes:

- PSV – Pressure Support Ventilation
- PSV(TgV) – Pressure Support Ventilation with Target Volume
- PCV – Pressure Controlled Ventilation
- PCV(TgV) – Pressure Controlled Ventilation with Target Volume
- PCV(A) – Assisted Pressure Controlled Ventilation
- PCV(A+TgV) – Assisted Pressure Controlled Ventilation with Target Volume
- PCV-SIMV – Pressure Controlled Ventilation with Synchronized Intermittent Mandatory Ventilation
- PCV-MPV – Pressure Controlled Ventilation with MouthPiece Ventilation
- VCV – Volume Controlled Ventilation
- VCV(A) – Assisted Volume Controlled Ventilation
- VCV-SIMV – Volume Controlled Ventilation with Synchronized Intermittent Mandatory Ventilation
- VCV-MPV – Volume Controlled Ventilation with MouthPiece Ventilation
- CPAP – Continuous Positive Airway Pressure

The Vivo 65 can be used with the following patient circuit configurations:

- Dual limb circuit (adult or pediatric), connected to an integrated active exhalation valve, for internal measurement of expired volume, pressure and flow.
- Single limb circuit with external leakage port or external active exhalation valve.
- Circuit with mouthpiece interface.

1.2 Intended Use

To provide continuous or intermittent ventilatory support for the care of individuals who require mechanical ventilation.

1.3 Indications for Use

The Vivo 65 ventilator (with or without the SpO₂ sensor and CO₂ sensor) is intended to provide continuous or intermittent ventilatory support for the care of individuals who require mechanical ventilation. Specifically, the ventilator is applicable for pediatric through adult patients weighing more than 5 kg (11 lbs.).

The Vivo 65 with the SpO₂ sensor is intended to measure functional oxygen saturation of arterial hemoglobin (%SpO₂) and pulse rate.

The Vivo 65 with the CO₂ sensor is intended to measure CO₂ in the inspiratory and expiratory gas.

The device is intended to be used in home, institution, hospitals and portable applications such as wheelchairs and gurneys. It may be used for both invasive and non-invasive ventilation. The Vivo 65 is not intended to be used as a transport or critical care ventilator.

1.4 Contraindications

- The use of the Vivo 65 is contraindicated for patients who need to be ventilated with oxygen concentrations (FiO₂) higher than achievable when combining inlet from a low pressure oxygen source at 15 l/min with actual ventilator settings.
- Generally, after surgery, the surgeon should be consulted to avoid organ damage and help determine ventilator parameters that do not adversely affect hemodynamics or have a negative impact on the patient's health status.

Undesirable Side Effects



The Vivo 65 is not intended to be used as an emergency transport ventilator or critical care ventilator.

If the patient experiences chest discomfort, pain, severe headache or shortness of breath while using the Vivo 65, a physician or responsible clinician shall be contacted immediately.

1.5 About this Manual



Always read this manual before setting up and using the Vivo 65 or performing maintenance on the machine to ensure correct usage, maximum performance and serviceability.

Audience







This manual is intended for patients and other lay users operating the Vivo 65.



Care providers, clinical personnel, physicians and others who require a working knowledge of the Vivo 65 will find additional information on settings and functions in the Clinician's Manual.

Icons

In this manual, icons are used to highlight specific information. The meaning of each icon is explained in the table below.

ICON	EXPLANATION
	Warning! Risk of death or serious personal injury.
	Warning! Risk of electric shock.
	Warning Risk of Cross-contamination.
	Warning! Flammable material, risk of fire.
	Caution! Risk of equipment damage, loss of data, extra work, or unexpected results.
	Note Information that may be valuable but is not of critical importance, tips.
	Reference Reference to other manuals with additional information on a specific topic.

2 Safety Information

2.1 General User Precautions



- When a ventilator-dependent patient is treated outside of a health care facility (e.g., in the home setting) there should always be a trained caregiver present to respond to alarms or conditions the patient is unable to solve on his or her own (e.g., troubleshooting alarm conditions and taking appropriate corrective action). The home medical equipment provider will ensure that the family caregivers are appropriately trained in responding to alarms and taking appropriate corrective action prior to the patient's discharge from the health care facility to the home, and will provide ongoing training to new caregivers as required or indicated.
- Always have immediate access to an alternative means of ventilation, which is ready for use, to avoid patient death or serious injury.
- Failure to have an alternate means of ventilation can result in serious injury or patient death if ventilator fails.
- The Vivo 65 must be turned off and on at least every 90 days. This is necessary in order for the Vivo 65 to perform a complete self-test. The self-test automatically tests the alarm sound and certain components.
- If you are admitted to a hospital or are prescribed any other form of medical treatment, always inform the medical staff that you are on mechanical ventilation treatment.
- Vivo 65 must only be used:
 - for the intended treatment in accordance with this operating manual and with the instructions given by the responsible clinical personnel;
 - in accordance with the operating conditions specified in this operating manual;
 - in original and unmodified form and only with accessories specified or approved by Breas Medical AB.

- Do not use the Vivo 65 in the event of suspected damage to the device, unexplainable or sudden pressure, performance or sound changes during operation, or if the delivered air from the Vivo 65 is abnormally hot or emits an odor. In these cases, contact the patient's responsible care provider for an inspection.
- The Vivo 65 may not work properly if any part has been dropped, damaged or submerged in water.
- Inadequate use of device or accessories may cause loss of treatment or decreased performance.
- The Vivo 65 therapy settings must always be based on medical advice and must be carried out by authorized clinical personnel only. When changing treatment settings or changing to another device, a clinical assessment must be performed to determine if blood gas measurement needs to be performed.
- Always perform the procedure "Inspecting the Vivo 65 before Use" on page 40 before use.
- The Vivo 65 can be used for life-supporting treatment provided an emergency equipment (e.g. resuscitation bag) is available, and that one of the following configurations is used for surveillance of ventilator-dependent patient breathing:
 - Dual limb patient circuit and insert with integrated exhalation valve: The Vivo 65's internal measurement and monitoring of exhaled volume must be supervised.
 - Single limb with leakage patient circuit: The Vivo 65's monitoring of exhaled volume must be supervised
 - Single limb with exhalation valve patient circuit: The CO₂ sensor or an external EtCO₂ monitor (capnometer) must be used. The CO₂ sensor must be connected between the patient and the exhalation valve to be able to measure exhaled gases. The CO₂ monitor shall fulfil the ISO 80601-2-55 standard (Medical electrical equipment - Particular requirements for the basic safety and essential performance of respiratory gas monitors).
- Make sure that accessories are compatible with the Vivo 65 before use.



- All of the physiological alarms of the Vivo 65 must be set at safe levels that will effectively warn the user of any risk. The alarm levels should be assessed considering the patient settings. Any change of settings or components may require the readjustment of the alarm levels.
- Setting the alarm sound level below that of the ambient sound level can impede recognition of alarm conditions.
- Handle the Vivo 65 with care.
- Do not use the Vivo 65 while in the carry bag.
- Do not use the Vivo 65 with nitric oxide, helium or helium mixtures.
- The Remote Start/Stop accessory is not to be used in Paediatric mode. Ensure that the Remote Start/Stop is disconnected when entering Paediatric mode.

2.2 Electrical Safety



- Do not operate the Vivo 65 if it has a damaged power cord or casing.
- To avoid electrical shock, disconnect the electrical supply to the Vivo 65 before cleaning. Do not immerse the Vivo 65 into any fluids.
- If a multiple portable socket-outlet is used, it must not be placed on the floor.
- Do not use more than one multiple portable socket-outlet or extension cord.
- If a portable multiple socket-outlet or extension cord is used, it must be checked that it is fully functional.
- The operator must not touch accessible contacts of connectors and the patient simultaneously.
- Nurse Call must only be connected to a safety extra low voltage system with an isolation from mains voltage which complies with the requirements of IEC 60601-1.
- The aspects of electromagnetic compatibility must be considered. The Vivo 65 should not be used adjacent to or stacked with other equipment; if adjacent or stacked use is necessary, the Vivo 65 should be observed to verify normal operation in that configuration. Mobile or transportable radio transmitters may interfere with the Vivo 65. Guidance for safe installation of the Vivo 65 can be found in “Emission and Immunity Declaration” on page 196.
- If a portable AC power supply is used, make sure that the voltage variations are within the operating limits of the Vivo 65. See “Power Supply” on page 192 for AC operating limits.
- Use of accessories, transducers and cables other than those specified or provided by Breas could result in increased electromagnetic emissions or decreased electromagnetic immunity of this equipment and result in improper operation.

2.3 Environmental Conditions



- Do not use the Vivo 65 in any toxic environment.
- Do not use the Vivo 65 in environments where there are explosive gases or other flammable anesthetic agents present.
- The air flow for breathing produced by the Vivo 65 can be as much as 7°F (4°C) higher than room temperature. Caution should be exercised if the room temperature is greater than 97°F (36°C).
- If a room humidifier is used, place it at least 6 feet (2 meters) away from the Vivo 65.
- The performance of the Vivo 65 may deteriorate at ambient temperatures below -4°F (-20°C) and above 104°F (40°C). However, the treatment shall always be started in an ambient temperature warmer than 41°F (5°C).



- MR Unsafe.
Do not use or store the Vivo 65 in a magnetic resonance (MR) environment. Use of the Vivo 65 in an MR environment may result in malfunction of the Vivo 65 and pose unacceptable risk to the patient, medical staff or other persons.
- Do not expose the Vivo 65 to rain or snowfall.



- Do not use the Vivo 65 while positioned in a warm place, such as direct sunlight or close to a radiator.
- The device complies with the EMC requirements of standards. Measures should include but not be limited to:
 - normal precautions with regard to relative humidity and conductive characteristics of clothing in order to minimize the build-up of electrostatic charges.
 - avoiding the use of radio emitting devices closer than 1 meter to the Vivo 65. Radio emitting devices include cellular or cordless telephones, microwave ovens and high-frequency surgery apparatus.

- Avoid using RFID devices closer than 1 meter to the Vivo 65.
- Avoid using the Vivo 65 within 1 meter of electronic article surveillance (EAS) system antennae.
- Unsteady indicated values for delivered volumes or pressures and the occurrence of alarm conditions without apparent cause may be an indication of a loss of performance due to electromagnetic disturbances. Follow the instructions above and the guidance provided in “Emission and Immunity Declaration” on page 196 to mitigate the effects of electromagnetic disturbances.
- The Vivo 65, any accessories and all replaced parts must be disposed of in accordance with the local environmental regulations regarding the disposal of used equipment and waste.
- The performance of the Vivo 65 and treatment of the patient may deteriorate if the operation conditions in “Technical Specifications” on page 176 are not fulfilled. Do not use the Vivo 65 immediately after storage or transport outside the recommended operating conditions.

2.4 Usage of Patient Circuit



- The Vivo 65 can be used with the following circuits:
 - Dual limb circuit (Adult use, 22 mm), connected to an integrated active exhalation valve
 - Dual limb circuit (Pediatric use, 15 mm), connected to an integrated active exhalation valve
 - Single limb circuit (with optional single limb insert) for an external active exhalation valve
 - Single limb circuit (with optional single limb insert) for an external leakage port
 - Circuit with mouthpiece interface
- For the Vivo 65 to deliver treatment according to settings, it is important that the selection of the patient circuit type is correctly set.
- The pressurized air from the Vivo 65 causes a continuous flow of air to exhaust from the leakage ports or exhalation valve, flushing exhaled gas from the circuit. The Vivo 65 should be turned on and the function of the leakage port or exhalation valve should be checked before use.
- Do not breathe in the connected patient circuit unless the Vivo 65 is turned on and operating properly.
- Do not use patient hoses or tubes made of static or electrically conductive material.
- Always make sure that the patient circuit and joined parts are undamaged and correctly connected, in order to avoid unwanted leakage.
- Always perform a pre-use test when the patient circuit or insert is replaced or modified.
- Patient connected parts and all filters must be replaced regularly to ensure correct function of the Vivo 65. All replaced parts must be disposed of according to local environmental regulations regarding the disposal of used equipment and parts.

- Patient circuits used with the Vivo 65 shall have the following characteristics:
 - Length: Max 6 feet (2 meters).
 - Connector: 22 mm.
 - Resistance: Max 2 mbar at 40 l/min.

If an active exhalation valve is used:

- Inner diameter of the exhalation valve control pressure tube: 3 mm.
- The exhalation valve must be of the type that is open (letting the exhaled patient air out) when unpressurized by the control pressure.

By conducting a pre-use test (see “Performing the Pre-use Test” on page 41), the compatibility of the complete patient circuit configuration with the Vivo 65 can be verified. If a pre-use test is successfully performed the circuit configuration meets the required characteristics.

- The leakage from the mask or leakage port should be at least 12 l/min at 4 cmH₂O, to prevent rebreathing of exhaled air. The recommended leakage is 20 to 50 l/min at 10 cmH₂O pressure.
- Periodically check for moisture in the patient circuit. When present, remove the moisture. Before attempting to dry the circuit, disconnect it from the Vivo 65 to ensure no water flows back into the Vivo 65.
- When using the Vivo 65 invasively, the low volume alarm and the low breath rate alarm must be carefully set, to ensure safe use.
- The use of equipment such as endotracheal tubes, oral/nasal tubes, adaptors, etc. with small inner diameters or high resistance filters (such as humidifiers) increases the resistance in the patient circuit which may interfere with the operation of the patient disconnect function. It may also interfere with the device trigger function. The impact can be reduced by conducting a pre-use test properly. (See “Performing the Pre-use Test” on page 41.)
- In case of invasive application, the use of an appropriate external heated humidifier or HME (Heat and Moisture Exchanger, artificial nose)/HCH (Hygroscopic Condenser Humidifier) is recommended.

- Make sure that the exhalation valve or the leakage port is never blocked or obstructed.
- Do not leave long lengths of air tubing around the top of the bed. It could twist around the patient's head or neck while he or she is sleeping.
- Always follow the instructions of the mask manufacturer.
- The Vivo 65 is equipped with a rebreathing alarm. The alarm is not a substitute for operator vigilance in ensuring that the leakage port or exhalation valve remains clear at all times. Periodically check the patient circuit during therapy.
- In general, as pressure decreases, the potential of rebreathing increases. Lower pressures produce less flow through the leakage port which may not clear all CO₂ from the circuit to prevent rebreathing.
- To reduce the risk of rebreathing CO₂, make sure that the leakage port or active exhalation valve is present as close as possible to the patient connection.
- Contact Injuries: Skin irritation may occur due to prolonged exposure to either a mask (if used) or the SpO₂ module.
- Always use a new patient circuit when the Vivo 65 is to be used by a new patient.



The Vivo 65 and its packaging do not contain any natural rubber latex.

2.5 Usage of Filters



- Always use the Vivo 65 with patient air inlet filters installed. Only use the Vivo 65 with accessories recommended by Breas.
- Replace or clean the filters regularly to ensure correct function of the Vivo 65. Failure to replace or clean a dirty filter may cause the Vivo 65 to operate at higher temperatures than intended. A dirty filter may be caused by dust or animal hair in the home environment.
- When operating the Vivo 65, make sure that the air inlet and filters are not obstructed or occluded. The use of a high resistance bacterial filter on the output of the device may interfere with the operation of the patient disconnect function. It may also interfere with the device trigger function. The impact can be reduced by conducting a pre-use test properly. (See “Performing the Pre-use Test” on page 41.)
- When adding or removing any kind of filter, always perform a pre-use test.



-

2.6 Humidification



- Humidification must only be used if this has been prescribed by your physician. The Vivo 65 therapy settings must always be prescribed by a physician or other licensed health care professional, and be carried out by authorized clinical personnel.
- When using an external heated humidifier, it should be located below the Vivo 65 and the patient to prevent injury from accidental spillage.
- When using a humidifier or nebulizer, any patient air filter will need more frequent replacement to prevent increased resistance or blockage.
- During transportation of the Vivo 65, the humidifier must be disconnected.
- If the condensation in the patient circuit is excessive, the use of a heated humidifier may require the installation of a water trap in the circuit. The water trap prevents any condensed water in the patient circuit from running into the patient airways and causing personal injury.
- When adding or removing a HME (Heat and Moisture Exchanger, artificial nose) or HCH (Hygroscopic Condenser Humidifier), always perform a pre-use test.
- Any humidifier connected to the Vivo 65 must comply with ISO 8185.
- Any HME connected to the Vivo 65 must comply with ISO 9360.



- The use of an HME or an external humidifier may require readjustment of the Vivo 65 low-pressure alarm.
- Certain HMEs and HCHs are sufficient to provide humidification when the Vivo 65 is used invasively. Check specific suppliers' recommended use.



The Vivo 65 has been tested and validated with the Fisher & Paykel MR850 heated humidifier.

2.7 Cleaning and Maintenance



- The Vivo 65 should be cleaned and maintained in accordance with this operating manual. (See “Cleaning and Maintenance” on page 169.)
- Do not attempt to autoclave or sterilize the Vivo 65 main unit.
- The Vivo 65 should undergo maintenance, service and control procedures, as well as any applicable upgrades, in accordance with Breas service instructions.
- The Vivo 65 shall only be repaired or modified in accordance with Breas service manuals, technical bulletins, and any special service instructions, by service technicians authorized by Breas Medical AB.
- Do not under any circumstances attempt to open, service or repair the Vivo 65 yourself. If you do so, the manufacturer will no longer be responsible for the performance and safety of the Vivo 65. Furthermore, no guarantees will be valid.

2.8 Usage of Oxygen



- Always follow the oxygen provider's instructions.
- The presence of oxygen can speed up combustion of inflammable materials.
- At a fixed flow rate of supplemental oxygen flow, the inhaled oxygen concentration will vary, depending on the pressure delivered, the patient's breathing pattern, mask selection and leak rate. To monitor the oxygen concentration the FiO_2 sensor (part no. 006347) is recommended.
- When oxygen is used with the Vivo 65, the oxygen flow must be turned off when the Vivo 65 is not operating. Oxygen delivered into the patient tubing may accumulate within the machine enclosure. Oxygen accumulated in the machine enclosure will increase the risk of fire.
- Do not use a humidifier between the oxygen source and the ventilator, in order to humidify the oxygen flow.
- Ventilate the room adequately.
- Do not smoke in a room where oxygen is being used.
- Naked light bulbs and other sources of ignition must be kept a minimum of 6 feet (2 meters) away from the oxygen cylinder or any part of the patient circuit.
- Supplemental oxygen with a flow up to 15 l/min can be added by an oxygen source with rotameter such as oxygen cylinder or a central oxygen supply system.
- Do not use aerosols or solvents close to the oxygen supply, even when the oxygen supply is shut off.



- Supplemental oxygen flow must not exceed 15 l/min. or 100 kPa.
- The oxygen concentration in the delivered air has influence on the volume measurement of the Vivo 65. This measurement is based on a normal oxygen concentration of 21%. If the oxygen concentration is higher, the monitored inspired volume will deviate from the actual volume as follows:
 - 40% oxygen concentration: -2.5% deviation
 - 60% oxygen concentration: - 5% deviation
 - 80% oxygen concentration: -7.5% deviation

3 Product Description

3.1 Main Components

The Vivo 65 system contains the following components:

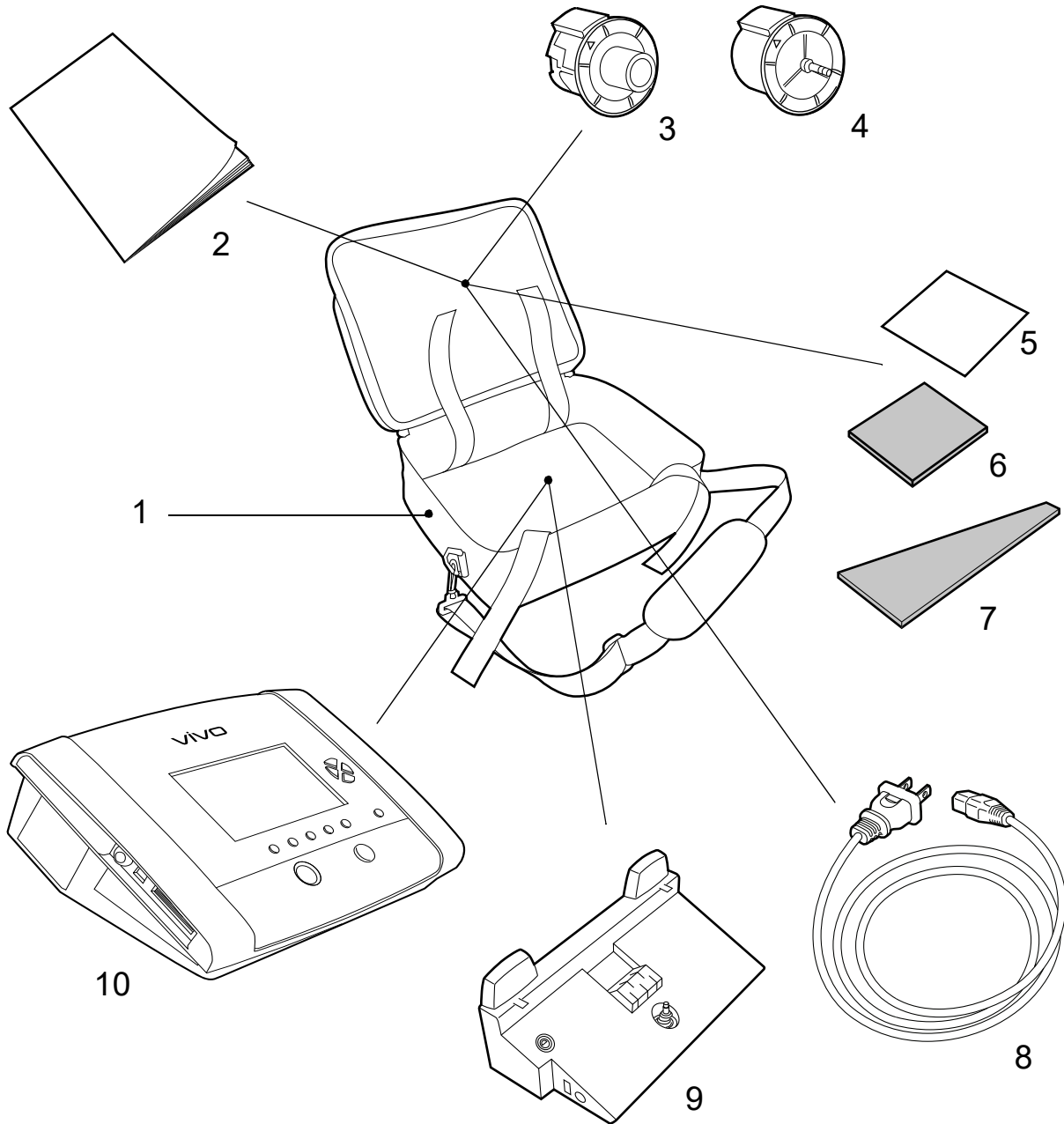

No.	COMPONENT	FUNCTION	PART NO.
1	Carry bag	Storage for transportation	006343
2	Users manual	Operating information	006088
3*	Dual limb insert	Insert for the dual limb patient circuit, enables integrated measurement of exhaled gas, volume and flow. Adult or pediatric use.	Adult: 005523 (disposable) Pediatric: 005525 (disposable)
4	Single limb insert	Connection for ventilator and single limb circuit, with external exhalation valve connector	005521
5	Filter (white)	Inlet air filtration	004910
6	Filter (grey)	Inlet air filtration	004909
7	Cooling air inlet filter (grey)	Inlet air filtration	006435
8	Power cord		005432
9*	Click-on battery		004559
10	Vivo 65 main unit		

* Optional



The Vivo 65 and its packaging do not contain any natural rubber latex.

3.2 The Vivo 65's Front Panel

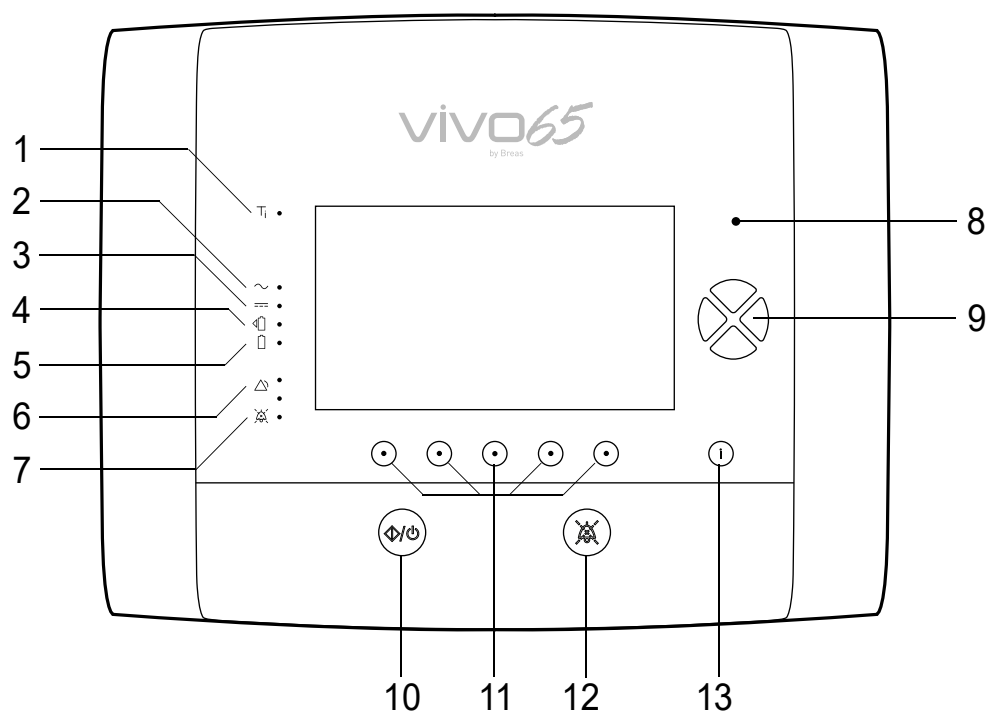







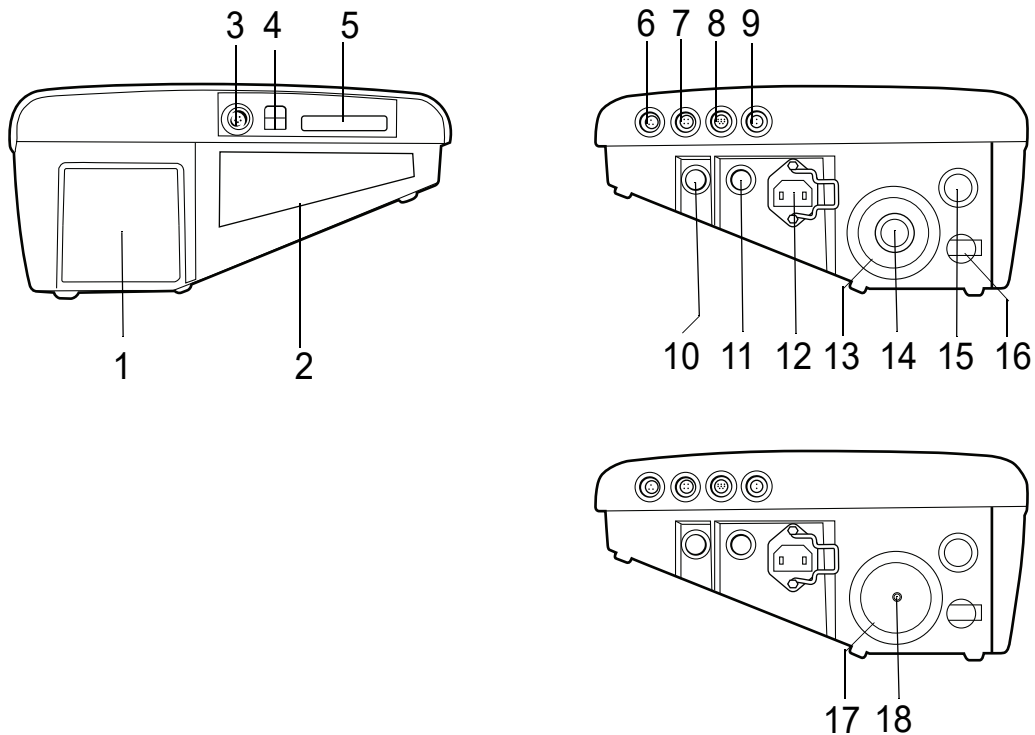





No.	LED	FUNCTION
1	Trigger	Patient triggered breath indication
2	AC	Power source: AC
3	External DC	Power source: External DC
4	Click-on battery	Power source: Click-on battery
5	Internal battery	Power source: Internal battery
6	Alarm	Alarm indication (red or yellow)
7	Audio pause	Paused alarm sound indication
8	Sensor	Ambient light sensor





No.	USER BUTTONS	FUNCTION
9	Navigation/Setting	Navigation in current menu selection/Define settings
10	Start/Stop	Start/Stop ventilation treatment
11	Function/Navigation	Function according to display
12	Audio Pause	Pause the alarm sound
13	Information	Show/Hide information

3.3 The Vivo 65's Side Panels



No.	ITEM	FUNCTION	COLOR/ SYMBOL
1	Patient air inlet	Air path in, replaceable filters Attention: Make sure that nothing can block the patient air inlet on the side of the Vivo 65. Read “Placing the Vivo 65” on page 32 for more information.	
2	Cooling air inlet	Inlet internal cooling, cooling air filter	
3	Nurse call / Remote alarm	Connection for nurse call	
4	USB data connection port	Data connection (PC and the Vivo 65. The data connection port is only to be used by your care provider)	













No.	ITEM	FUNCTION	COLOR/ SYMBOL
5	Memory card slot	Ventilator Memory Data download	
6	Remote Start/Stop	Connection for remote start/stop module	 
7	SpO ₂ interface port	Connection for SpO ₂ module	 SP O₂
8	CO ₂ interface port	Connection for CO ₂ sensor	 
9	FiO ₂ interface port	Connection for FiO ₂ sensor	 
10	Standby button	Power on and off	
11	External DC inlet	Connection for external DC power source	
12	AC power inlet	Connection for AC power source Attention: Read the chapter “Connecting the Vivo 65 to AC Power” on page 34.	
13	Dual limb insert	Changeable connection for dual limb circuit, with integrated exhalation valve Insert for Adult use Insert for Pediatric use	 
14	Dual limb exhaled air inlet	Exhaled air connection for dual limb circuit	













No.	ITEM	FUNCTION	COLOR/ SYMBOL
15	Patient air outlet	Connection for patient circuit	
16	Oxygen inlet port	Connection for low pressure/ bleed-in oxygen source	 
17	Single limb insert	Changeable connection for single limb circuit	
18*	Exhalation valve control pressure outlet	Connection for external exha- lation valve control pressure tube	

* *Optional*

3.4 Equipment Designation and Safety Labels

Symbols Explanation

	Dual limb insert, disposable: Do not reuse
	Single limb insert (optional): Exhalation valve control pressure outlet
	Unlocked insert
	Locked insert
	Click-on battery connector. Attention: Make sure not to touch this connector while simultaneously touching the patient.
	Patient air inlet Attention: Make sure that nothing can block the patient air inlet on the side of the Vivo 65. Read “Placing the Vivo 65” on page 32 for more information.
	Internal and Click-on battery Attention: Read the chapter “Using Batteries” on page 92.
	Battery
	Product number
	Serial number
	Date of Manufacture
	Read user instructions.

	This product must not be exposed to open fire.
	This product should be recycled.
	Read “Disposal” on page 175 for information about recycling and disposal.
	Degree of protection provided by enclosure. The Vivo 65 is rated IP22, which means it is protected from touch by fingers and objects greater than 12 mm, and protected from water spray less than 15 degrees from vertical.
	Class II equipment; double insulation.
	Body floating (IEC 60601-1 Type BF, Isolated Applied Part)
	(Symbol only applicable in U.S.) Caution: U.S. Federal law restricts this device to sale by or on the order of a licensed health-care practitioner.
	Conforms to IEC 60601-1:2012 including ANSI/AAMI ES60601-1:2005 Conforms to CAN/CSA C22.2 No. 60601-1:08.
 	CE marking applies in accordance with the directive MDD 93/42/EEC.
	Manufacturer
	Keep Dry



Fragile*



This Side Up*

* *Appears on box / packaging.*

4 Preparing the Vivo 65 for Use

 Read the chapter “Safety Information” on page 8 before setting up the Vivo 65.

4.1 Checking the Vivo 65 before First Use

When using the Vivo 65 for the first time, follow the instructions below:

- 1** Check that all main components and ordered accessories have been delivered. (Refer to the packing note or the invoice, if available.)
- 2** Ensure that the equipment is in good condition.
- 3** If stored more than one month, connect the Vivo 65 to the power supply to recharge the internal battery. (See “Charging the Batteries” on page 93 for further instructions.)
- 4** Check that the grey and white (optional use) air filters are installed.

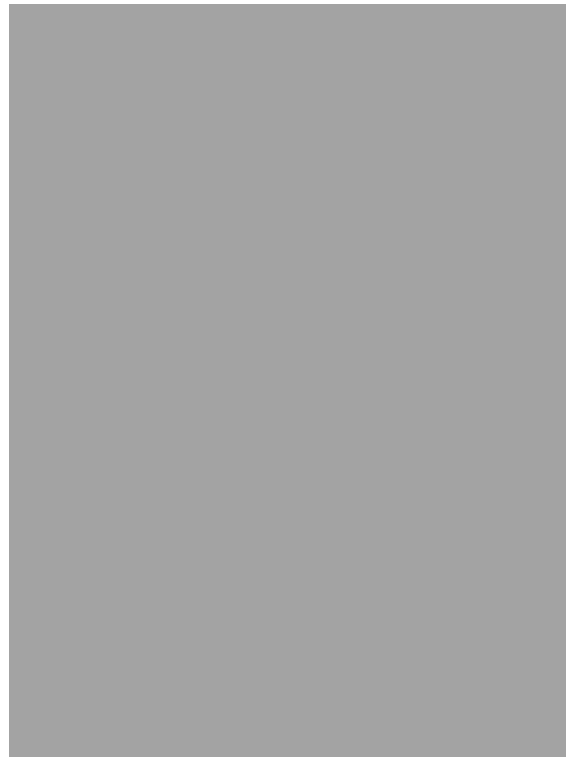

5 Check that the grey cooling air inlet filter is installed.

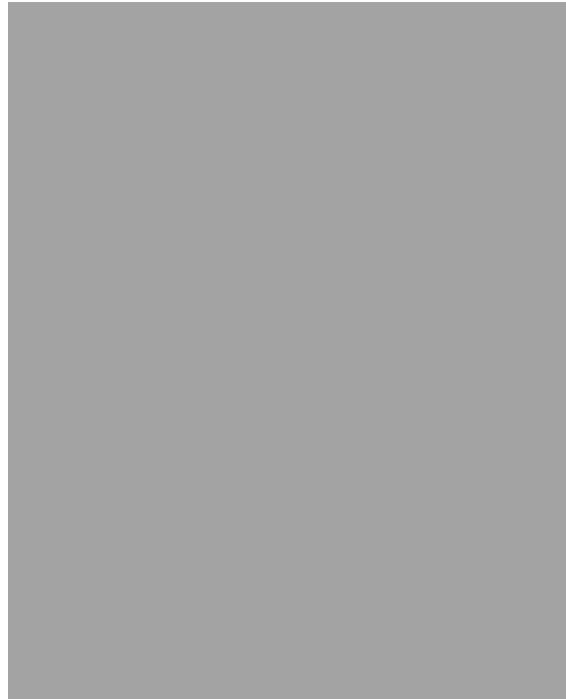

4.2 Placing the Vivo 65

Read the chapter “Environmental Conditions” on page 12 carefully to make sure all conditions are met and considered.

1 Place the Vivo 65 on a solid, flat surface. The Vivo 65 should be placed lower than the patient in order to prevent the device from falling on the patient, as well as preventing condensated water from reaching the patient.

2 Make sure that nothing can block the patient air inlets on the side of the Vivo 65.

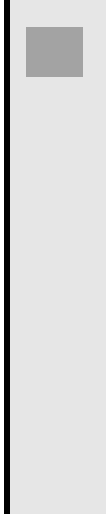

- 
- Do not place the Vivo 65 on a soft surface that will prevent the air flow underneath the device.

Never cover the device.



- Always position the Vivo 65 so that it is easy to remove the power cord from the AC power inlet.

4.3 Connecting the Vivo 65 to AC Power

 Read the chapter “Electrical Safety” on page 11 carefully to make sure all conditions are considered and met.

1 Plug the power cord into the power inlet of the Vivo 65.



2 Secure the power cord using the restraining clip.



3 Connect the power cord to the power source.



 To isolate the Vivo 65 from the supply mains, remove the power cord from the AC power inlet.

4.4 Connecting the Patient Circuit

Read the chapter “Usage of Patient Circuit” on page 14 carefully to make sure all conditions are considered and met.

- Make sure that the correct patient circuit type is selected when connecting the insert and patient circuit.
- In MPV breath mode the patient circuit type setting is not available. Circuit with mouthpiece interface shall always be used in MPV breath mode.

The Vivo 65 can be used with the following circuits:

- Dual limb circuit (Adult use, 22 mm), connected to the Vivo 65’s integrated exhalation valve
- Dual limb circuit (Pediatric use, 15 mm), connected to the integrated exhalation valve
- Single limb circuit with external active exhalation valve; requires an optional single limb insert
- Single limb circuit with external leakage port
- Circuit with mouthpiece interface

Connect Patient Circuit Insert

The choice of insert makes it possible to connect the Vivo 65 to either a dual limb pediatric circuit, a dual limb adult circuit or a single limb circuit. The Vivo 65 automatically detects which insert has been installed. Before

connecting an insert, make sure the configurations of patient mode and patient circuit type are correct:

INSERT TYPE	PATIENT MODE	PATIENT CIRCUIT TYPE
Dual limb insert Adult	Adult	<ul style="list-style-type: none"> • Dual limb circuit with integrated exhalation valve (Dual) • Single limb circuit with leakage port (Leakage) • Circuit with mouthpiece interface
Dual limb insert Pediatric	Pediatric	<ul style="list-style-type: none"> • Dual limb circuit with integrated exhalation valve (Dual) • Single limb circuit with leakage port (Leakage) • Circuit with mouthpiece interface
Single limb insert (optional)	Adult / Pediatric	<ul style="list-style-type: none"> • Single limb circuit with active exhalation valve (Exh. valve) • Single limb circuit with leakage port (Leakage) • Circuit with mouthpiece interface

- To optimize the treatment with Vivo 65's pediatric settings in Pediatric mode when using a dual limb circuit, always use a pediatric dual limb insert and a 15 mm dual limb circuit. Using a pediatric dual limb insert with an adult (22 mm) dual limb circuit may impair the performance of the ventilation treatment and deteriorate the measurement precision of the exhaled air.
- Always perform a pre-use test after changing the patient circuit type and/or insert.
- An incorrect combination of patient circuit type and insert will result in a Circuit Type/Insert Mismatch alarm, with medium alarm priority.
- An incorrect combination of patient mode and insert will result in a Patient Mode/Insert Mismatch alarm, with medium alarm priority.
- Do not remove the gasket that is placed inside the Vivo 65's insert socket. Removing the gasket will result in a patient circuit leakage and a Disconnection alarm and/or Exhalation Valve Control Error alarm.

1 Connect the insert to the ventilator. While connecting, the lock indicator on the insert's lock-ring should point to the unlock symbol on the Vivo 65.

2 Lock the insert by turning the lock-ring clockwise, so that the indicator points to the lock symbol on the ventilator.



3 Make sure a “click” sound is heard when fastening the lockring. This sound ensures that the insert is correctly attached.

Unlock and disconnect in reverse order.



Connect Dual Limb Circuit for Integrated Exhalation Valve

1 Connect one patient tube to the patient air outlet of the ventilator.



2 Connect the other patient tube to the exhaled air inlet of the Vivo 65.



3 Connect the other end of the patient circuit to an HME or patient interface.

Connect a Single Limb Circuit with Leakage Port

The leakage from the mask or leakage port should be at least 12 l/min at 4 cmH₂O, to prevent rebreathing of exhaled air. The recommended leakage is 20 to 50 l/min at 10 cmH₂O pressure.

1 Connect the patient circuit to the patient air outlet of the ventilator.



2 Connect the other end of the patient circuit to the leakage port or patient interface.

Connect a Single Limb Circuit with Active Exhalation Valve

1 Connect the patient circuit to the patient air outlet of the ventilator.



2 Connect the control pressure tubing to the exhalation valve, and to the exhalation valve control pressure outlet of the Vivo 65.



3 Connect the other end of the patient circuit to an HME or patient interface.

4.5 Inspecting the Vivo 65 before Use

Inspection of Device

- Check that there is no visible damage.
- Check that the surface is clean.

Inspection of Cables

- Check that all cables are recommended by Breas.
- Check that the cables are undamaged.
- Check that the cables are properly connected.

Inspection of Placement

- The Vivo 65 shall be placed on solid flat surface below the patient level. (See “Placing the Vivo 65” on page 32.)
- Make sure that nothing can block the air inlet at the side.

Inspection before Use

Always make the following checks before using the Vivo 65:

- 1 Connect a patient circuit to the Vivo 65.
- 2 Connect the Vivo 65 to the power source.
- 3 Turn on the Vivo 65 main power using the Standby button on the side panel.
- 4 Ensure that the treatment settings and alarm settings are adjusted as prescribed, and that the correct patient circuit type is selected.
- 5 Perform a pre-use test by following the instructions on the display.

 Pre-use test cannot be performed in MPV breath mode. Skip this step if MPV breath mode is used.

- 6 Press the Start/Stop button on the front panel until the progress bar is filled.
- 7 Check that a short double sound signal is heard. If there is no signal, do not use the Vivo 65 and contact your service provider.
- 8 Disconnect the power cord for more than 5 seconds. Check that the device switches to the internal battery (or click-on battery if connected) and that an information message is shown on the screen together with an audible warning. If this is not the case, contact your service provider.

9 Reconnect the power cord. Check that the device switches to the power source and that an information message is shown on the screen together with an audible warning.

10 Connect the patient and adjust and fit the mask if one is used.

4.6 Performing the Pre-use Test

The pre-use test is used for detecting the type and characteristics of the patient circuit that is connected to the Vivo 65. The resistance and compliance of the patient circuit are measured and calculated. This will be used to compensate for pressure and compliance deviations during treatment.

The patient shall not be connected during the pre-use test.

Always perform a new pre-use test if the patient circuit configuration or insert has been changed.

- If the pre-use test has not been performed, the Vivo 65 will operate with default patient circuit compensation.
- Pre-use test cannot be performed in MPV breath mode.

Actions at Pre-Use Test Failure

At the end of the pre-use test the individual results for leakage, resistance and compliance are shown.

Failure Due To Incorrect Leakage

Indication: **Leakage: Fail**

- 1** Check the ventilator set-up (circuit, filters, humidifier, etc.) for leakage.
- 2** Ensure that all connectors are tightly fitting.
- 3** Run the pre-use test again.
- 4** Replace the circuit if the test is failed repeatedly.

Failure Due To Incorrect Resistance or Compliance

Indication: **Resistance: Fail or Compliance: Fail**

- 1** Check the ventilator set-up (circuit, filters, humidifier, etc.) for blockage or pinched tubing.

- 2 Run the pre-use test again.

If the pre-use test is continually failed due to resistance or compliance, it is permitted to use the ventilator but be aware that the pressure (resistance) or volume (compliance) delivered to the patient may not meet with the specified accuracy.

The ventilator will apply the default values to compensate for circuit resistance and compliance. These values will deviate from the values for the circuit in use. Ensure that the delivered ventilation is closely monitored.

Failure Due To Dual Limb Insert Calibration

Indication: **Dual: Fail**

- 1 Check the patient circuit for leakage.
- 2 Replace the insert.

5 How to Use the Vivo 65

 Read the chapter “Safety Information” on page 8 before using the Vivo 65.

When the Vivo 65 is handed over to the patient, the physician in charge or hospital staff must instruct the patient in how the unit works.

5.1 Turning the Vivo 65 On and Off

Turn On and Enter Operating Mode

1 Make sure the power source is connected and secured by the restraining clip.



2 Turn on the Vivo 65 and enter Standby mode by pressing the Standby button on the side panel.



3 To start treatment and enter operating mode first press and hold the Start/Stop button on the front panel.



Release the Start/Stop button when the progress bar is filled.



Stopping Treatment and Turning Off

1 To stop treatment and enter Standby mode, first press and hold the Start/Stop button on the front panel.



2 Release the Start/Stop button on the front panel when the progress bar is filled.



3 Press the Audio Pause button within 10 seconds. Press the button firmly.



4 When the Vivo 65 is not in an active treatment mode, press the Standby button on the side panel to change the unit to a low power standby state.



5.2 Using the Menu

Navigating with the Buttons

Use the five navigation buttons and the up and down buttons on the panel in order to navigate the Vivo 65 menu.



The navigation buttons are used to view the different sections indicated above each one. The same navigation button can also be used to view additional information in some sections, or it can be designated a temporary function while an event window is active.









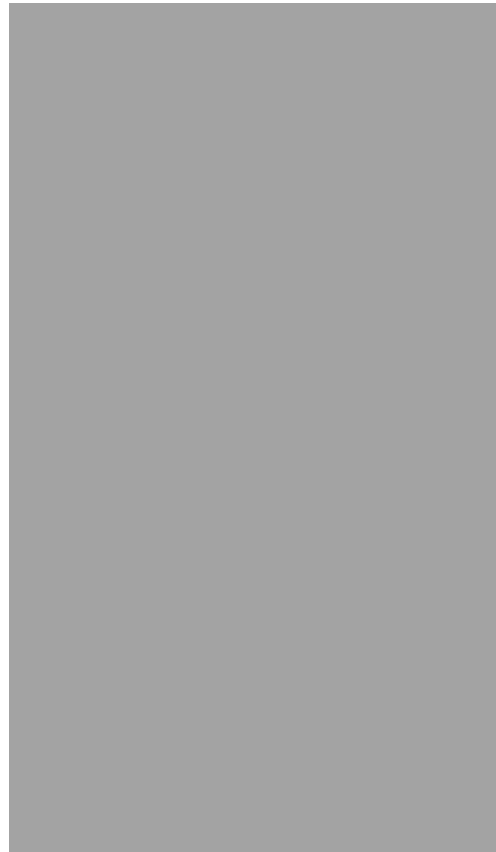





 Use the up or down button to enter the menu list.

Use the arrow buttons (up and down) to navigate up or down in a menu list, or to select different parameters.

Use the arrow buttons (left and right) to alter parameters, or enter and exit sub sections.

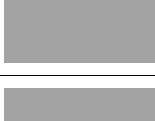
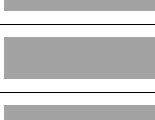

Symbols Used in the Menu

SYMBOL	DESCRIPTION
	Internal battery level
	Click-on battery level
	Home Mode activated
	Dual limb circuit for integrated exhalation valve selected (Dual)
	Single limb circuit with leakage port selected (Leakage)
	Single limb circuit with active exhalation valve selected (Exh. valve)
	MPV breath mode selected. Circuit with mouthpiece interface shall be used.
	SpO ₂ connected
	FiO ₂ connected
	CO ₂ connected
	Multiple pages
	Multiple content available
	High priority alarm event in history list
	Medium priority alarm event in history list

Overview Menu

The Vivo 65 menu has the following section layout:

Main	
Setup	<u>Icon explanation</u>
Setup 1-2	Page
Alarm	Sub menu
Alarm Settings 1-2	
Alarm/Event History	
Monitor	
Others	
Device memory	
Patient Operating Time	
Device Settings	
Time and Date	
Device Information	

The Vivo 65 Display

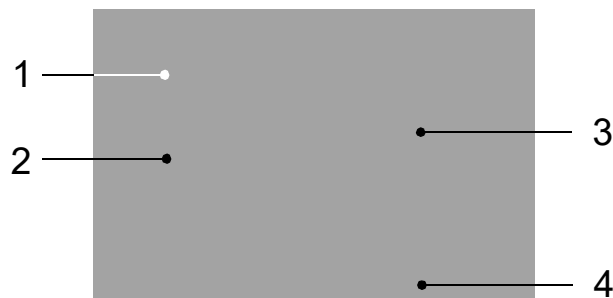

1. Pressure and Volume Indicators

The bargraphs are used to display current pressure, PEEP, P_{peak} , pressure and volume alarm limits, and inspired/expired tidal volume.

The red lines represent the low and high pressure alarms, the low and high tidal volume alarms.

2. Icon/Alarm Message

Information icons are presented here to give a quick overview of the Vivo 65 basic status. (See “Symbols Used in the Menu” on page 47.)

3. Screen Title and Context Area

Screen title, page number (if more than one subpage exists in the section) and time are displayed.

4. Navigation Field

This field is mainly used for displaying the section layout of the menu, and determines the function of each navigation button.

Depending on the current operation, the navigation buttons can be assigned temporary functions such as “Yes” or “Next”, depending on which operation is active.

The Setup Section



In the Setup section, treatment parameters can be altered. See “Functions and Parameters in the Vivo 65” on page 60.

Home Adjust

The Home Adjust function can be activated by the care provider. When activated, the care provider can unlock treatment parameters and define a limited setting range. The patient and lay care giver can change these settings within the limited range when the Vivo 65 is in Home mode.

Black color indicates that the parameter is possible to adjust within a certain settings range. Grey color indicates that the parameter is locked.

The Alarm Section



In the Alarm section, the alarm parameters can be altered. (See “Alarms” on page 111 for more information.)

The Alarm/Event History screen displays all events that have been logged, as well as alarms that have occurred. Alarms are colored according to priority, and are maintained when the Vivo 65 is powered down.

The manufacturer-configured state of physiological alarms may be retrieved by selecting “Reset to basic settings” on the Mode screen in Standby mode.

The Monitor Section

The monitoring section provides display of treatment data.



The monitoring screen contains a bargraph field that displays current Pressure, PEEP and P_{peak} pressure and volume alarm limits, and inspired/expired tidal volume. The monitoring field displays all available values for the current treatment mode. (In most other screens, except for the curve and trend view, a small monitoring field is displayed with 8 values.) See “Monitored Values in the Vivo 65” on page 54 for a description on the monitored values.

The Others Section

Device Memory

A memory card can be used for transferring data or settings from the internal memory. See “Transferring Data with a Memory Card” on page 91 for instructions on how to transfer memory data on a card and erase memory data.

Patient Operating Time

Shows the number of hours a patient has been using the Vivo 65 for breathing therapy.

Device Settings

General settings for the Vivo 65:

- Display Light:
 - On — keeps the display lit regardless of use
 - Auto — adjusts the light intensity depending on the ambient light
 - Delayed — dims the display after 30 seconds or more depending on the mode and battery setup

If any button is pressed or any alarm occurs, the display light will return to normal again.

- Light Intensity (setting range: 1-9, where 1 is the lowest and 9 is the highest light intensity setting. In cases where Display Light is set to “Auto”, the Light Intensity setting will not be available)

If the light intensity is set too low, ambient light could cause difficulties in reading the alarm text.

- Auto Keypad Lock (On, Off)

Time and Date

- Time (set time: hours and minutes)
- Time Format (choose between 24 h or 12 h am/pm format)
- Date (set date: year, month and day)
- Date Format (choose between yyyy-mm-dd, dd/mm/yyyy, mm/dd/yyyy format)

Device Information

- Device Operating Time (hours)
- Firmware Version
- Language Package
- Lang. Package Version
- AC (On/Off)
- External DC (V)
- Serial Number

5.3 Monitored Values in the Vivo 65



Values monitored by the Vivo 65 can be found in the monitoring screen.

P_{peak}

The P_{peak} displays the highest pressure that is recorded during the inspiratory phase.



PEEP

The PEEP displays the pressure at the end of the expiratory phase.



P_{mean}

The P_{mean} displays the calculated mean value of pressure during a complete ventilatory cycle (inspiratory + expiratory phase).



Leakage

The Leakage displays the total leakage (intentional and unintentional) as calculated at expiratory pressure level.



MV_i

The MV_i displays the Inspired Minute Volume calculated as Inspired Tidal Volume multiplied with the Total Breath Rate.

This value is only displayed in the monitoring field if the patient circuit type is Exhalation valve (single limb) or if MPV breath mode is used.

The Vivo 65 is suitable for treatment of patients that require a minute volume between 1 and 30 litres.

MV_e

The MV_e displays the Expired Minute Volume calculated as Expired Tidal Volume multiplied with the Total Breath Rate.

This value is only displayed in the monitoring field if the patient circuit type is Dual limb or Leakage circuit.

When the Vivo 65 is used non-invasively, the MV_e can differ from the exhaled minute volume from the patient due to leaks around the mask.

Vt_i

The Vt_i displays the Inspired Tidal Volume that is delivered to the patient during each breath.

This value is only displayed in the monitoring field if the patient circuit type is Exhalation valve circuit (single limb) or if MPV breath mode is used.

Vt_e

The Vt_e displays the Expired Tidal Volume that the patient exhales during each breath.

This value is only displayed in the monitoring field if the patient circuit type is Dual limb or Leakage circuit.

When using a leakage patient circuit, the Expired Tidal Volume is a calculated value. When using a dual limb patient circuit, the Tidal Volume is measured in the dual limb insert.

When the Vivo 65 is used non-invasively the Vt_e can differ from the exhaled tidal volume from the patient due to leaks around the mask.

FiO₂

The FiO₂ displays the fraction of inspired oxygen as measured at the air outlet of the Vivo 65. An FiO₂ sensor (part no. 006347) needs to be in place to measure and display this value (see “Using the Vivo 65 with the FiO₂ Sensor” on page 102)

% in TgV

The % in TgV displays the percentage of breaths where the actual delivered Tidal Volume matches with the set Target Volume (not calculated until 100 breaths are registered).

Total Rate

The Total Rate displays the actual total breath rate independent of whether the breaths are patient- or ventilator-triggered breaths.

Spont Rate

The Spont Rate displays the actual spontaneous breath rate.



% Spont

The % Spont displays the percentage of spontaneous breaths calculated since the ventilator was last started (not calculated until 100 breaths are registered).



SpO₂ (Oxygen Saturation)

The SpO₂ displays the patient's oxygen saturation as measured with the SpO₂ module.

- The oximeter in the Vivo 65 is calibrated to display functional oxygen saturation.
- For data regarding the oxygen probe's range of peak wavelengths, max optical power and usage, please refer to the respective probe manual.
- Environmental factors may influence the function or accuracy of the pulse oximeter, such as ambient light, physical movement, diagnostic testing, low perfusion, electromagnetic interference, dysfunctional haemoglobin, presence of certain dyes and inappropriate positioning of the pulse oximeter probe.

Pulse Rate

The Pulse Rate displays the patient's pulse rate as measured with the SpO₂ module.

I:E

The I:E displays the ratio between the length of the inspiration and the length of the expiration.

Insp. Time

The Insp. Time displays the duration of the inspiratory cycle, measured from the start of inspiration to the start of expiration.

Rise Time

The Rise Time displays the duration of the pressure or volume increase, measured from the start of inspiration until the set pressure or volume has been reached.

EtCO₂

The EtCO₂ displays the end-tidal carbon dioxide, measured on the last portion of the exhaled volume that is passing through the CO₂ sensor.



InspCO₂

The InspCO₂ displays the inspired carbon dioxide.



5.4 Functions and Parameters in the Vivo 65

All the parameters used for controlling the breathing by the Vivo 65 are listed below.

Inspiratory Pressure (Insp. Pressure)

ITEM	DESCRIPTION
Definition	<p>The Inspiratory Pressure setting is used to define the airway pressure during the inspiratory phase.</p> <p>In the PCV-SIMV mode, this setting defines the inspiratory pressure for the mandatory breaths controlled by the ventilator.</p>
Modes	PSV, PSV(TgV), PCV, PCV(TgV), PCV(A), PCV(A+TgV), PCV-SIMV, PCV-MPV
Setting min	4 cmH ₂ O (Adult), 4 cmH ₂ O (Pediatric)
Setting max	50 cmH ₂ O (Adult), 35 cmH ₂ O (Pediatric)
Setting resolution	0.5 below 10 cmH ₂ O, 1.0 above 10 cmH ₂ O
Display	

PEEP (Positive End Expiratory Pressure)

ITEM	DESCRIPTION
Definition	The PEEP setting is used to define the airway pressure at the end of the expiratory phase.
Modes	PSV, PSV(TgV), PCV, PCV(TgV), PCV(A), PCV(A+TgV), PCV-SIMV, VCV, VCV(A), VCV-SIMV
Setting min	Off, 2 cmH ₂ O (leakage circuit, circuit with external/integrated active exhalation valve, single limb exhalation valve for Pediatric VCV)
Setting max	20 cmH ₂ O (Adult, Paediatric), Pressure - 2 cmH ₂ O or Min Pressure -2 cmH ₂ O.
Setting resolution	0.5 below 10 cmH ₂ O, 1.0 above 10 cmH ₂ O
Display	

PScalc

ITEM	DESCRIPTION
Definition	PScalc displays the pressure above the PEEP pressure applied to the patient in PCV/PSV mode.
Modes	PSV, PCV, PCV(A), PCV-SIMV
Display	

Breath Rate

ITEM	DESCRIPTION
Definition	<p>The Breath Rate setting defines the minimum number of breaths the Vivo 65 will deliver as long as no inspiratory trigger effort from the patient is detected. The cycles will be ventilator-initiated breaths.</p> <p>The combination of the Breath Rate and Inspiratory Time setting is limited by the I:E ratio 2:1.</p>
Modes	PCV, PCV(TgV), PCV(A), PCV(A+TgV), VCV, VCV(A), PCV-MPV, VCV-MPV
Setting min	4 bpm (Adult), 6 bpm (Pediatric), 0 bpm (MPV breath mode)
Setting max	40 bpm (Adult), 60 bpm (Pediatric)
Setting resolution	1 bpm
Display	

SIMV Rate

ITEM	DESCRIPTION
Definition	<p>The SIMV Rate setting is used in the SIMV ventilation modes, for defining the frequency of mandatory, ventilator-controlled breaths. The mandatory breaths can be either triggered by an inspiratory effort from the patient, or ventilator-initiated.</p> <p>The SIMV Rate setting determines the SIMV cycle time.</p> <p>The combination of the SIMV Rate and Inspiratory Time setting is limited by the I:E ratio 2:1.</p>
Modes	PCV-SIMV, VCV-SIMV
Setting min	4 bpm (Adult), 6 bpm (Pediatric)
Setting max	40 bpm (Adult), 60 bpm (Pediatric)
Setting resolution	1 bpm
Display	

Inspiratory Time (Insp. Time)

ITEM	DESCRIPTION
Definition	<p>The Inspiratory Time setting defines the length of each inspiration from start of inspiration to cycling off to expiration.</p> <p>In the PCV-SIMV and VCV-SIMV modes, this setting is used for defining the inspiration length of the mandatory breaths controlled by the ventilator.</p> <p>The combination of the Inspiratory Time and Breath Rate or SIMV Rate settings is limited by the I:E ratio 2:1 to 1:99.</p>
Modes	PCV, PCV(TgV), PCV(A), PCV(A+TgV), PCV-SIMV, PCV-MPV, VCV, VCV(A), VCV-SIMV, VCV-MPV
Setting min	0.3 s
Setting max	5 s (Adult), 2 s (Pediatric)
Setting resolution	0.1 s
Display	

I:Ecalc

ITEM	DESCRIPTION
Definition	The I:Ecalc displays the calculated I:E ratio based on the Breath Rate and Inspiratory Time settings.
Modes	PCV, PCV(TgV), PCV(A), PCV(A+TgV), PCV-SIMV, PCV-MPV, VCV, VCV(A), VCV-SIMV, VCV-MPV
Display	

Backup Inspiratory Time (Backup Insp. Time)

ITEM	DESCRIPTION
Definition	<p>The Backup Inspiratory Time setting defines the length of each inspiration delivered during ventilator-triggered backup ventilation, initiated by the set Backup Rate.</p> <p>The combination of the Backup Inspiratory Time and Backup Rate setting is limited by the I:E ratio 2:1.</p>
Modes	PSV, PSV(T _g V)
Setting min	0.3 s
Setting max	5 s (Adult), 2 s (Pediatric)
Setting resolution	0.1 s
Display	

Sigh

ITEM	DESCRIPTION
Definition	<p>A Sigh is a breath where an increased % of the set pressure or volume is delivered to the patient. The frequency of the Sigh breaths is selectable and settable to be delivered by the device every 50, 100, 150, 200 or 250 mandatory or assisted breaths.</p> <p>If the High Pressure alarm or the High Tidal Volume alarm is active, the Sigh function will be disabled. Once the alarm condition has been resolved, the Sigh function will continue operating.</p>
Modes	PSV, PSV(TgV), PCV, PCV(TgV), PCV(A), PCV(A+TgV), VCV, VCV(A)
Setting min	Sigh rate: Off, every 50 breaths. Sigh %: 125% of actual set pressure or volume.
Setting max	Sigh rate: Every 250 breaths. Sigh %: 200% of actual set pressure or volume. Limited to 50 cmH ₂ O or 2000 ml (Adult), 35 cmH ₂ O or 500 ml (Pediatric).
Setting resolution	50 breaths (frequency). 25% (pressure and volume)
Display	

Rise Time

ITEM	DESCRIPTION
Definition	<p>The Rise Time setting controls the speed of the pressure/volume increase from start of inspiration to set inspiratory pressure/tidal volume.</p> <p>A low setting will give a faster pressure/volume increase and therefore a longer plateau at the set inspiratory pressure/tidal volume. A high setting will give a slow increase and therefore a shorter plateau.</p> <p>In the VCV-SIMV mode, two different Rise Time settings are made, one for mandatory ventilator-controlled breaths and one for additional pressure support breaths triggered by the patient.</p>
Modes	PSV, PSV(TgV), PCV, PCV(TgV), PCV(A), PCV(A+TgV), PCV-SIMV, PCV-MPV, VCV, VCV(A), VCV-SIMV, VCV-MPV
Setting min	<p>1 (PSV & PCV, PCV-SIMV, PCV-MPV, VCV-SIMV)</p> <p>50% of the inspiration time (Min. 0.3 s) (VCV, VCV-SIMV, VCV-MPV)</p>
Setting max	<p>9 (PSV & PCV, PCV-SIMV, PCV-MPV, VCV-SIMV)</p> <p>90% of the inspiration time, Off (=100%) (VCV, VCV-SIMV, VCV-MPV)</p>
Setting resolution	<p>1 (PSV & PCV),</p> <p>10% (VCV)</p>
Display	

Inspiratory Trigger (Insp. Trigger)

ITEM	DESCRIPTION
Definition	<p>The inspiratory trigger setting defines the patient's effort required to initiate a ventilator assisted breath. When the patient starts a breath, an increasing flow is created in the patient circuit. If the patient's effort reaches the set inspiratory trigger level an inspiration is initiated. If the patient cannot trigger a breath, the ventilator will deliver breaths according to the set Backup Rate, Breath Rate or SIMV Rate.</p> <p>The Assisted breath modes in PCV and VCV are turned off if the inspiratory trigger is set to Off.</p>
Modes	PSV, PSV(TgV), PCV(A), PCV(A+TgV), PCV-SIMV, PCV-MPV, VCV(A), VCV-SIMV, VCV-MPV
Setting min	1
Setting max	9(PSV,PCV-SIMV,PCV-MPV,VCV-SIMV, VCV-MPV), 9, Off (PCV & VCV)
Setting resolution	1 (setting 1 is the most sensitive and 9 is the least sensitive)
Display	

SIMV Support Pressure (Sup. Pressure)

ITEM	DESCRIPTION
Definition	The SIMV Support Pressure setting is used in the SIMV ventilation modes to define the inspiratory pressure for the pressure support breaths triggered by the patient.
Modes	PCV-SIMV, VCV-SIMV
Setting min	4 cmH ₂ O
Setting max	50 cmH ₂ O (Adult), 35 cmH ₂ O (Pediatric).
Setting resolution	0.5 below 10 cmH ₂ O, 1.0 above 10 cmH ₂ O
Display	

Expiratory Trigger (Exp. Trigger)

ITEM	DESCRIPTION
Definition	<p>The Expiratory Trigger setting defines the moment when the ventilator will cycle from the inspiratory to the expiratory phase.</p> <p>In PCV-SIMV and VCV-SIMV modes, this setting is applicable to the pressure support breaths that are triggered by the patient.</p>
Modes	PSV, PSV(T _g V), PCV-SIMV, VCV-SIMV
Setting min	1 (10% decrease of peak flow)
Setting max	9 (90% decrease of peak flow)
Setting resolution	1 (setting 1 cycles off early and 9 cycles off late)
Display	

Minimum Inspiratory Time (Min Insp. Time)

ITEM	DESCRIPTION
Definition	The Minimum Inspiratory Time setting defines a minimum length for each inspiration. If the Minimum Inspiratory Time is set to Off, the length of the inspiration is dependent on the set Expiratory Trigger or the maximum inspiratory time.
Modes	PSV, PSV(TgV)
Setting min	Off, 0.3 s
Setting max	3 s (Adult), 2 s (Pediatric)
Setting resolution	0.1 s
Display	

Maximum Inspiratory Time (Max Insp. Time)

ITEM	DESCRIPTION
Definition	The Maximum Inspiratory Time setting defines a maximum length for each inspiration. If the Maximum Inspiratory Time is set to Off, the length of the inspiration is dependent on the set Expiratory Trigger and/or minimum inspiratory time.
Modes	PSV, PSV(TgV)
Setting min	0.3 s
Setting max	3 s, Off (Adult), 2 s, Off (Pediatric)
Setting resolution	0.1 s
Display	

Backup Rate

ITEM	DESCRIPTION
Definition	<p>The Backup Rate setting defines the minimum number of breaths the Vivo 65 will deliver in case of prolonged apnea and as long as no inspiratory trigger effort from the patient has been detected. The cycles will be ventilator-initiated breaths.</p> <p>The combination of the Backup Rate and Backup Inspiratory Time setting is limited by the I:E ratio 2:1.</p>
Modes	PSV, PSV(TgV)
Setting min	4 bpm (Adult), 6 bpm (Pediatric)
Setting max	40 bpm (Adult), 60 bpm (Pediatric)
Setting resolution	1 bpm
Display	

Target Volume

ITEM	DESCRIPTION
Definition	<p>The Target Volume setting defines the tidal volume that the Vivo 65 will aim for while ventilating the patient in a pressure mode. To aim for the preset volume, the Vivo 65 will adapt the Inspiratory Pressure between two adjustable pressure limits: Min Pressure and Max Pressure.</p> <p>When Target Volume is active, the mode field on the Vivo 65 display will indicate “(TgV)”.</p> <p>■ If Target Volume is used with a patient circuit with an active exhalation valve, leakage may be misinterpreted by the Vivo 65 as an increase of tidal volume. This will lead to a decrease of the Inspiratory Pressure (the Inspiratory Pressure will not be lower than the set Min Pressure). This may result in hypoventilation as the true delivered tidal volume will decrease both as a result of the leakage and the decrease in Inspiratory Pressure.</p> <p>This does not occur if a patient circuit with leakage port is used.</p>
Modes	PSV(TgV), PCV(TgV), PCV(A+TgV)
Setting min	Off, 300 ml (Adult) Off, 50 ml (Pediatric)
Setting max	2000 ml (Adult), 300 ml (Pediatric)
Setting resolution	10 below 500 ml, 50 above 500 ml
Display	

Max Pressure

ITEM	DESCRIPTION
Definition	The Max Pressure setting is only used when Target Volume is activated. Max Pressure defines the upper pressure limit up to where the Vivo 65 can increase the pressure to reach the set Target Volume. If Target Volume is not reached at Max Pressure, the Vivo 65 will continue to ventilate at this Max Pressure setting.
Modes	PSV(TgV), PCV(TgV), PCV(A+TgV)
Setting min	Min Pressure
Setting max	50 cmH ₂ O or Max Pressure (Adult) 35 cmH ₂ O or Max Pressure (Pediatric)
Setting resolution	0.5 below 10 cmH ₂ O, 1.0 above 10 cmH ₂ O
Display	

Min Pressure

ITEM	DESCRIPTION
Definition	The Min Pressure setting is only used when Target Volume is activated. Min Pressure defines the lower pressure limit down to where the Vivo 65 can decrease the pressure to maintain the set Target Volume. If the actual volume is above Target Volume at Min Pressure, the Vivo 65 will continue to ventilate at this Min Pressure setting.
Modes	PSV(TgV), PCV(TgV), PCV(A+TgV)
Setting min	4 cmH ₂ O
Setting max	50 cmH ₂ O or Max Pressure (Adult), 35 cmH ₂ O or Max Pressure (Pediatric)
Setting resolution	0.5 below 10 cmH ₂ O, 1.0 above 10 cmH ₂ O
Display	

Tidal Volume

ITEM	DESCRIPTION
Definition	<p>The Tidal Volume setting defines the volume that will be delivered by the Vivo 65 for each breath.</p> <p>In VCV-SIMV mode, this setting is applicable to the mandatory breaths that are controlled by the ventilator.</p>
Modes	VCV, VCV(A), VCV-SIMV, VCV-MPV
Setting min	300 ml (Adult) 50 ml (Pediatric)
Setting max	2000 ml (Adult), 300 ml (Pediatric)
Setting resolution	10 below 500 ml, 50 above 500 ml
Display	

Flow Pattern

ITEM	DESCRIPTION
Definition	The Flow Pattern setting is used to define how the flow will be delivered during inspiration. When a square wave pattern is applied the flow will be constant throughout the complete inspiratory cycle. When a decelerating wave pattern is applied the flow will be higher at the start of the inspiratory cycle and decrease towards the end.
Modes	VCV, VCV(A), VCV-SIMV, VCV-MPV
Setting range	Square, Decelerating
Display	

CPAP

ITEM	DESCRIPTION
Definition	The CPAP setting defines the pressure that will be applied to the airways.
Modes	CPAP
Setting min	4 cmH ₂ O
Setting max	20 cmH ₂ O
Setting resolution	0.5 below 10 cmH ₂ O, 1.0 above 10 cmH ₂ O
Display	

5.5 Modes in the Vivo 65

In the Modes section of the Vivo 65 display, the operator selects the Ventilation mode, Breath mode, Patient mode and Device mode for the treatment.

Standby and Operating Mode

Standby mode is defined as the state of the Vivo 65 when AC is connected and the Standby button has been pressed, but without starting the Vivo 65 with the Start/Stop button.

Operating mode is defined as the state of the Vivo 65 when the blower is operating and producing an air flow.

Switch between operating and standby mode by starting/stopping the Vivo 65 (see “Turning the Vivo 65 On and Off” on page 43).

Some operations (such as setting time and date) are only available in Standby mode.

Patient Mode

The Vivo 65 can be operated in either Adult mode or Pediatric mode. The Vivo 65 is intended for treatment of pediatric patients who weigh more than 11 lbs (5 kg).

In Pediatric mode, some ventilator parameters, for example Breath Rate, Inspiratory Time and Tidal Volume have special setting limits. The default settings and alarm limits of the Vivo 65 are preset when the patient mode is altered.

- To optimize the treatment with Vivo 65’s pediatric settings in Pediatric mode when using a dual limb circuit, always use a pediatric dual limb insert and a 15 mm dual limb circuit. Using a pediatric dual limb insert with an adult (22 mm) dual limb circuit may impair the performance of the ventilation treatment and deteriorate the measurement precision of the exhaled air.
- An incorrect combination of patient mode and insert will result in a Patient Mode/Insert Mismatch alarm, with medium alarm priority.

Ventilation and Breath Modes

The ventilation and breath modes are used for controlling the ventilation treatment with the Vivo 65. The ventilation mode selected can be either Pressure, Volume or CPAP. It is used in combination with the Support, Assist/Control, SIMV or MPV breath mode.

The following combinations of ventilation and breath modes can be selected for the Vivo 65:

- PSV – Pressure Support Ventilation
- PSV(TgV) – Pressure Support Ventilation with Target Volume
- PCV – Pressure Controlled Ventilation
- PCV(TgV) – Pressure Controlled Ventilation with Target Volume
- PCV(A) – Assisted Pressure Controlled Ventilation
- PCV(A+TgV) – Assisted Pressure Controlled Ventilation with Target Volume
- PCV-SIMV – Pressure Controlled Ventilation with Synchronized Intermittent Mandatory Ventilation
- PCV-MPV – Pressure Controlled Ventilation with MouthPiece Ventilation
- VCV – Volume Controlled Ventilation
- VCV(A) – Assisted Volume Controlled Ventilation
- VCV-SIMV – Volume Controlled Ventilation with Synchronized Intermittent Mandatory Ventilation
- VCV-MPV – Volume Controlled Ventilation with MouthPiece Ventilation
- CPAP – Continuous Positive Airway Pressure

PSV – Pressure Support Ventilation

In the PSV mode, the patient's spontaneous breathing is assisted by the ventilator. The patient controls the start of inspiration through the inspiratory trigger and the start of exhalation by the expiratory trigger.

The set pressure is used as a target pressure, if the flow is decreased to the expiratory trigger level before the set pressure is reached, the expiration starts.

When an inspiration is started either when the patient triggers a breath, or when the backup rate setting initiates an inspiration in case of a prolonged apnea, the ventilator delivers a flow up to a certain preset pressure limit. In case of a patient initiated breath, the patient continues the breath for as long as they wish and cycles off when a percentage of drop in peak inspiratory flow (expiratory trigger) has been reached.

Spontaneous breaths stop and an exhalation starts in three cases:

- The inspiration flow has dropped to the value set for expiratory trigger.
- The inspiration time has reached the limit for maximal inspiration time or 3 seconds.
- The limit for the high-pressure alarm is reached.

PSV(TgV) – Pressure Support Ventilation with Target Volume

The PSV(TgV) mode acts as the PSV mode but with an added regulation of the pressure. Target volume is a feature that automatically adapts the pressure to make sure that the Vivo 65 delivers the desired set target volume to the patient. The delivered volume is compared to the set target volume on a breath by breath basis. The delivered pressure for the next breath will be increased or decreased depending on the difference between the delivered volume and the set target volume. Automatic pressure adjustments will be made in between two adjustable limits (min pressure and max pressure) in order to deliver the optimal support to the patient.

 See “Target Volume” on page 76 for more information about Target Volume.

PCV – Pressure Controlled Ventilation

In the PCV mode the ventilation is controlled by the Vivo 65. This is done at the preset pressure, breath rate, inspiratory time, and rise time settings set by the operator.

The inspiration stops and an expiration starts in two cases:

- The inspiration time expires.
- The limit for the high pressure alarm is reached.

PCV(A) – Assisted Pressure Controlled Ventilation

In the PCV(A) mode the ventilation is controlled by the Vivo 65, but the patient has the possibility to start a breath through the Inspiratory Trigger. This patient triggered breath will be delivered with the inspiratory time, rise time and pressure setting set by the operator.

PCV(TgV) – Pressure Controlled Ventilation with Target Volume

The PCV(TgV) mode acts as the PCV mode, but with an added regulation of the pressure. Target volume is a feature that automatically adapts the pressure to make sure that the Vivo 65 delivers the desired set target volume to the patient. For every breath, the delivered volume is compared to the set target volume. The delivered pressure for the next breath will be increased or decreased depending on the difference between the delivered volume and the set target volume. Automatic pressure adjustments will be made in between two adjustable limits (min pressure and max pressure) in order to deliver the optimal support to the patient.

See “Target Volume” on page 76 for more information about Target Volume.

PCV(A+TgV) – Assisted Pressure Controlled Ventilation with Target Volume

The PCV(A+TgV) mode acts like the PCV(A) mode, but with an added regulation of the pressure. Target volume is a feature that automatically adapts the pressure to make sure that the Vivo 65 delivers the desired set target volume to the patient. The delivered volume is compared to the set target volume on a breath by breath basis. The delivered pressure for the next breath will be increased or decreased depending on the difference between the delivered volume and the set target volume. Automatic pressure adjustments will be made in between two adjustable limits (min pres-

sure and max pressure) in order to deliver the optimal support to the patient.



See “Target Volume” on page 76 for more information about Target Volume.

PCV-SIMV – Pressure Controlled Ventilation with Synchronized Intermittent Mandatory Ventilation

In the PCV-SIMV mode, the Vivo 65 synchronizes mandatory pressure-controlled breaths with the patient’s breathing efforts.

In this mode, the ventilator delivers mandatory pressure-controlled breaths with a preset breath frequency defined as the SIMV Rate. The SIMV Rate setting determines the length of the SIMV cycle.

For each SIMV cycle, there is an initial mandatory period in which the patient may trigger one mandatory breath. This mandatory period is always 80% of the SIMV cycle time. If the patient does not trigger a breath during this period, the ventilator will deliver one mandatory breath automatically in the end of the period.

Between the mandatory breaths, the patient may trigger spontaneous breaths until the next SIMV cycle begins. The ventilator will respond to the patient’s inspiration efforts with additional pressure support breaths. The inspiratory pressure of these support breaths is defined by the SIMV Support Pressure, together with the settings for Rise Time and Expiratory Trigger. The default value for SIMV Support Pressure is the Inspiratory pressure in PCV.

PCV-MPV – Pressure Controlled Ventilation with Mouth-Piece Ventilation

The PCV-MPV mode is tailored specifically for those patients that uses mouthpiece interface together with pressure controlled ventilation.

In MPV breath mode it is possible to set Breath Rate to zero so that breaths are only initiated when the patient triggers them using the mouthpiece. PEEP setting is not available but always set to Off so that no air blows from the mouthpiece when no breaths are delivered.

As the patient is not always connected to the ventilator several of the surveillance functions are not working in the same way as in other modes:

- Disconnection alarm is not available in MPV mode.
- Low Pressure alarm is only active during breaths.
- Apnea alarm is possible to set to longer times and is an important mean of surveillance to make sure that the patient gets ventilation support regularly.

When switching to MPV mode all alarms, except from High/Low Pressure Alarms, are automatically switched off to avoid false alarm triggering (when changing between profiles the alarm settings does not change to Off, but stays as defined in the profiles)



- The alarm levels must be assessed and adjusted considering the patients condition and treatment settings.
- MPV breath mode shall be used with a mouthpiece interface only.
- MPV breath mode shall not be used with ventilator dependent patients.

VCV – Volume Controlled Ventilation

In the VCV mode the ventilation is controlled by the Vivo 65. This is done with the preset tidal volume, breath rate, inspiratory time, and rise time settings set by the operator.

The inspiration stops and an expiration starts in two cases:

- The inspiratory time expires.
- The limit for the high pressure alarm is reached.

VCV(A) – Assisted Volume Controlled Ventilation

In the VCV(A) mode the ventilation is controlled by the Vivo 65, but the patient has the possibility to start a breath through the inspiratory trigger. This patient triggered breath will be delivered with the inspiratory time, rise time and tidal volume setting set by the operator.

VCV-SIMV – Volume Controlled Ventilation with Synchronized Intermittent Mandatory Ventilation

In the VCV-SIMV mode, the Vivo 65 synchronizes mandatory volume-controlled breaths with the patient's breathing efforts.

In this mode, the ventilator delivers mandatory volume-controlled breaths with a preset breath frequency defined as the SIMV Rate. The SIMV Rate setting determines the length of the SIMV cycle.

For each SIMV cycle, there is an initial mandatory period in which the patient may trigger one mandatory breath. This mandatory period is always 80% of the SIMV cycle time. If the patient does not trigger a breath during this period, the ventilator will deliver one mandatory breath automatically in the end of the period.

Between the mandatory breaths, the patient may trigger spontaneous breaths until the next SIMV cycle begins. The ventilator will respond to the patient's inspiration efforts with additional pressure support breaths. The inspiratory pressure of these support breaths is defined by the SIMV Support Pressure, together with the settings for Rise Time and Expiratory Trigger. The default value for SIMV Support Pressure is the Inspiratory pressure set in PCV or PSV.

VCV-MPV – Volume Controlled Ventilation with MouthPiece Ventilation

The VCV-MPV mode is tailored specifically for those patients that uses mouthpiece interface together with volume controlled ventilation.

In MPV breath mode it is possible to set Breath Rate to zero so that breaths are only initiated when the patient triggers them using the mouthpiece. PEEP setting is not available but always set to Off so that no air blows from the mouthpiece when no breaths are delivered.

As the patient is not always connected to the ventilator several of the surveillance functions are not working in the same way as in other modes:

- Disconnection alarm is not available in MPV mode.
- Low Pressure alarm is only active during breaths.

- Apnea alarm is possible to set to longer times and is an important mean of surveillance to make sure that the patient gets ventilation support regularly.

When switching to MPV mode all alarms, except from High/Low Pressure Alarms, are automatically switched off to avoid false alarm triggering (when changing between profiles the alarm settings does not change to Off, but stays as defined in the profiles)



- The alarm levels must be assessed and adjusted considering the patients condition and treatment settings.
- MPV breath mode shall be used with a mouthpiece interface only.
- MPV breath mode shall not be used with ventilator dependent patients.

CPAP – Continuous Positive Airway Pressure

In CPAP mode the Vivo 65 is applying a continuous positive pressure to the airways. The flow will automatically be adjusted to maintain the set CPAP level. CPAP mode can only be used when a leakage circuit is selected.

Sigh

When the Sigh feature is enabled the Vivo 65 will deliver a Sigh breath as configured by the prescriber at a certain preset frequency. A Sigh is a breath where an increased % of the set pressure or volume is delivered to the patient.

In Volume modes the Vivo 65 can deliver a Sigh using 125%, 150%, 175% or 200% of the set Tidal Volume. The Tidal Volume that will be used during the Sigh for the selected % will be displayed on the Setting screen.

In Pressure modes the Vivo 65 can deliver a Sigh using 125%, 150%, 175% or 200% of the set Inspiratory Pressure. The Inspiratory Pressure that will be used during the Sigh for the selected % will be displayed on the Setting screen.

The Sigh frequency can be set to occur once every 50, 100, 150, 200 or 250 mandatory or assisted breaths.



- In pressure modes (during the sigh breath), the high pressure alarm will automatically be set 10 cmH₂O above set sigh pressure (max 55 cmH₂O).
- In volume modes (during the sigh breath), the high pressure alarm will automatically be increased by the same percentage as the set sigh volume (max 55 cmH₂O).

5.6 Transferring Data between the Vivo 65 and a PC



Read the chapter “Electrical Safety” on page 11 carefully to make sure all conditions are met and considered.



Do not eject the memory card or disconnect the Vivo-PC data cable while the Vivo 65 is transferring data. Doing so may result in loss of data and/or damaged equipment.



In order to view and present patient data correctly, the Vivo 65 PC Software must be installed on the PC.



Instructions on how to manage data in the Vivo 65 PC Software can be found in the software help.

The Data Log

The Vivo 65 logs data on an internal memory. The log data is maintained when device is powered off or in case of power failure. When logs are filled up, the oldest data will be discarded. The data is stored in three different logs:

- Usage log, containing 1 year of data sampled and averaged every 24 hours. Data include non-clinical events, physiological and technical alarms, and settings.
- Breath log, containing 1 month of data sampled every breath. Only sampled during treatment. Data include clinical parameters.
- Detailed log, containing 24 hours of data sampled at 10 Hz. Only sampled during treatment. Data include flow and pressure data.

The data log can be transferred to the PC either by use of a memory card or by an USB cable:

Transferring Data with a Memory Card



The Vivo 65 can copy and transfer data to the memory card.

1 Insert the memory card in the memory card slot on the side of the Vivo 65. Make sure the memory card is properly inserted.

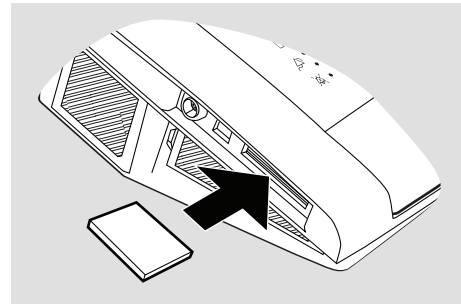

2 When the memory card is inserted, a pop-up window will appear on the Vivo 65's display. Press OK to start saving data on the memory card.

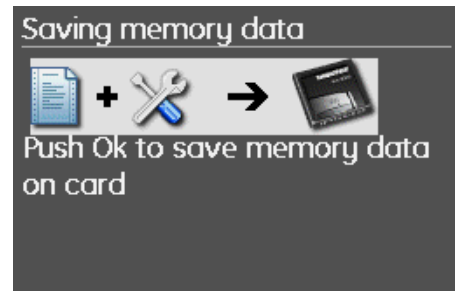

3 Wait while the Vivo 65 is saving to the memory card.

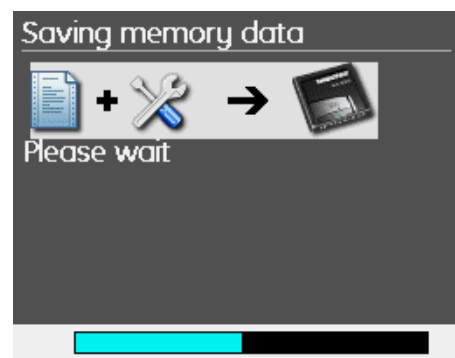

4 Connect the memory card reader/writer to a PC and insert the memory card.

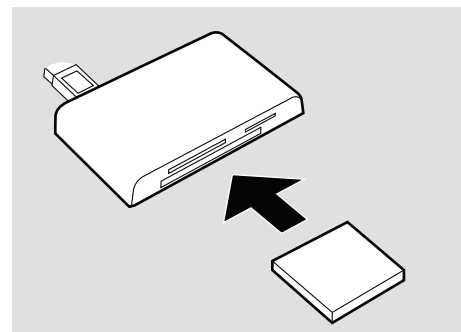

5.7 Using Batteries

Since all batteries, in general, degenerate over time, the recommendations below will ensure that the battery capacity of the Vivo 65 is maximized during its lifetime.

The internal and click-on batteries in the Vivo 65 are of the Lithium-ion type, which is a high performance battery. It has long expected lifetime, low weight in relation to its capacity and low self discharge.



See the Vivo 65 Service Manual on how to perform service on the batteries.

Power Source Priority

- 1 AC power
- 2 External DC
- 3 Click-on battery
- 4 Internal battery

When a power source fails or is disconnected, the Vivo 65 will switch to either the external DC (if installed), the click-on battery (if attached) or the internal battery and show a message in the display window.



The switchover to internal battery can be tested by disconnecting the AC power cord. Switchover is indicated by power source LED and information message on the screen.

Charging the Batteries



Do not charge the Vivo 65 while placed in the carry bag or other types of closed or non-ventilated spaces.

The batteries have no “memory effect” (with older battery types it was an advantage to fully discharge and charge the battery, otherwise they will “learn” not to use the full capacity). The new batteries perform best if no complete cycles are made. Therefore it is only an advantage to charge the battery as soon as an opportunity arises. The Vivo 65 internal battery can be used for up to 600 complete cycles, the click-on battery can be used for up to 500 complete cycles.

The internal and click-on batteries are automatically charged when connecting the Vivo 65 to the mains supply. To ensure that the batteries are fully charged, a maintaining charging cycle will be performed. The batteries are not charged when connecting the Vivo 65 to an external DC supply. While charging, the battery level will be animated. The batteries are only charged if the internal temperatures are between 32 to 113°F (0 to 45°C). High power consuming settings in combination with high ambient temperatures may make the battery temperature rise above 113°F (45°C).





Charging Times

BATTERY	CHARGER	TIME*
Internal battery	Vivo 65	3 h
Click-on battery	Vivo 65	5.5 h
Click-on battery	Click-on battery charger	3 h

* Times are based on charging empty batteries.

Battery Icons

When running on battery, the battery status is indicated by the following symbols:

SYMBOLS	BATTERY STATUS
	Full
	Medium
	Empty/Low
	Disconnected or malfunctioning
	Malfunctioning

Internal Battery

The internal battery is intended as a backup power source if the primary AC power source fails. It can also be used as a temporary power source.

For example during transportation between one stationary power source to another.

The battery level is displayed in the icon row, monitoring field.



Click-on Battery



The patient must not remove nor replace the click-on battery.

The click-on battery is intended as a power source during transportation, or if the primary AC power source fails.

The click-on battery can be replaced during treatment, provided that the internal battery is charged.

Connect the Click-on Battery

1 Use a thin stick to open the cover for the click-on battery connectors.

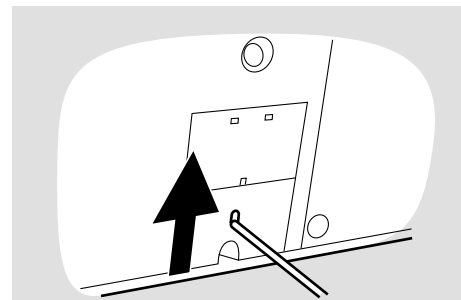

2 Make sure the cover is completely opened.

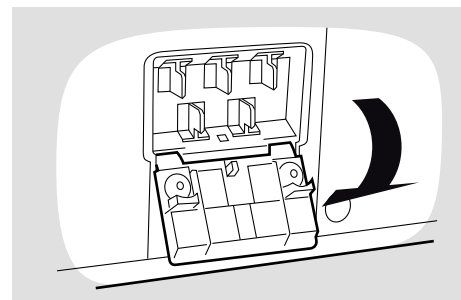

3 Hold the Vivo 65 as shown in the picture, in order to target the click-on battery holders (marked with circles).

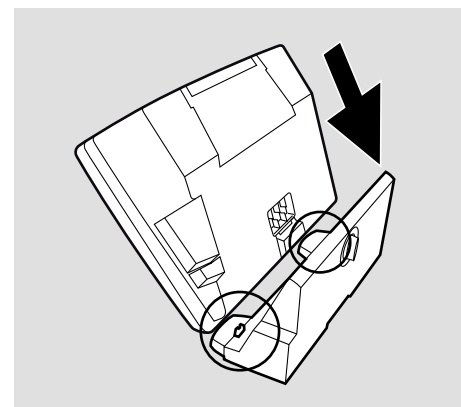

4 Tilt the Vivo 65 into an upright position.

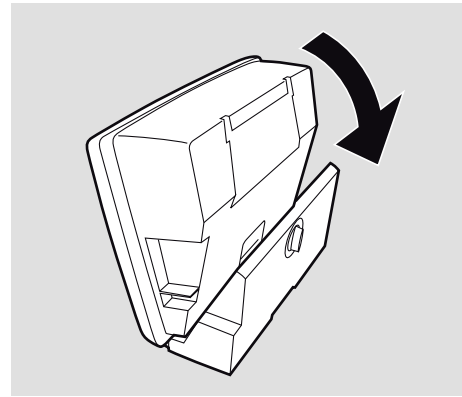

5 Once in position, a clicking sound should be heard.

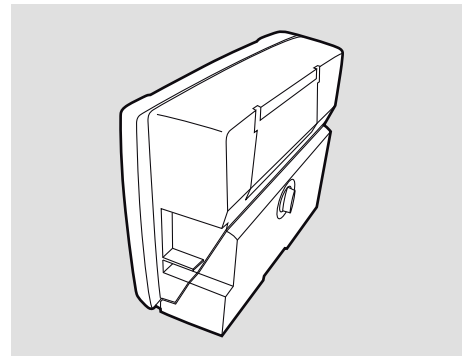

6 Use the screw to secure the click-on battery by pressing it in and turn clockwise.

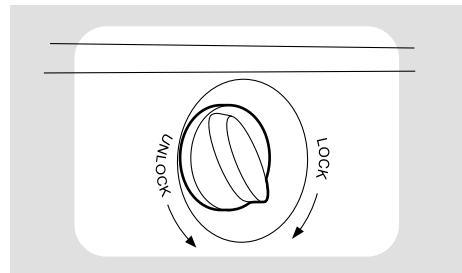

Remove the click-on battery in reverse order. Make sure the cover is closed after disconnecting the click-on battery.

Charging the Click-on Battery using Click-on Battery Charger

1 Connect the click-on battery charger to the click-on battery.

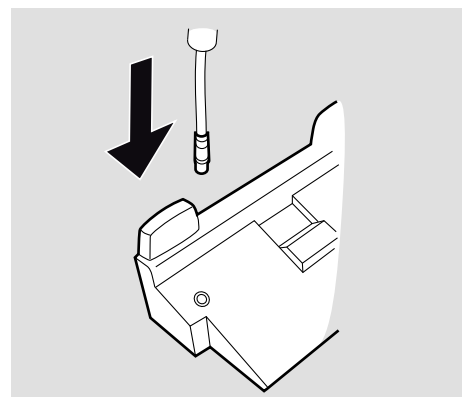

2 Connect the charger to the AC power supply.

To charge an empty click-on battery using the click-on battery charger takes about 3 hours.

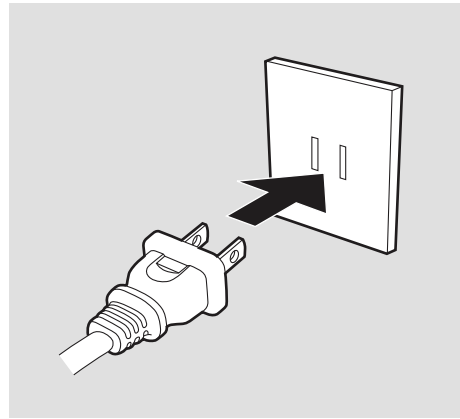

Battery Operating Time (Internal and Click-on)

The operation time is dependent on the battery condition, its capacity, the ambient air temperature and the Vivo 65 pressure setting. These data are based on new and fully charged batteries.

PARAMETER	EXAMPLE 1	EXAMPLE 2
VENTILATOR SETTINGS		
Patient Mode	Adult	Paediatric
Mode	VCV	PCV
Tidal Volume	800 ml	N/A
Inspiratory Pressure	N/A	30 cmH ₂ O
PEEP	5 cmH ₂ O	5 cmH ₂ O
Breath Rate*	20 bpm	30 bpm
Insp. Time*	1 s	0.6 s
I : E (Calculated)	1 : 2	1 : 2.3
Insp. Trigger	Off	Off
Rise Time	Off	4
Flow Pattern	Square	N/A
Display Light*	On	On
Light Intensity*	5	5
LUNG CHARACTERISTICS		
Resistance	5 hPa(l/s) ⁻¹ ±10%	200 hPa(l/s) ⁻¹ ±10%
Compliance	50 ml(hPa) ⁻¹ ±5%	3 ml(hPa) ⁻¹ ±5%
OPERATING TIME		

PARAMETER	EXAMPLE 1	EXAMPLE 2
Internal Battery	3.5 h	3.5 h
Click-on Battery	8 h	8 h

* *These ventilator settings affect the operating time significantly.*

Storing the Internal Battery and the Click-on Battery

Storage longer than one month should be initiated with half-charged batteries in order to maintain maximum capacity. Optimal storage temperature is 41 to 86°F (5 to 30°C).

External DC



Do not connect the Vivo 65 to a wheelchair unless the operating manual for the wheelchair permits this as this can affect the Vivo 65 performance and consequently result in patient death.



Only use a battery charger compliant to IEC 60601-1 if you are charging a battery that at the same time is connected to the Vivo 65.

The Vivo 65 can be operated from:

- a 12 V external DC source using the 12/24 V converter (part no. 004901).
- a 24 V external DC source using the external battery cable (part no. 004899).

With an external DC source connected, the Vivo 65 will automatically switch over to the external DC source if the mains power cord is removed or if the AC power supply fails. The external DC voltage level is shown under “Others”, “Device Information” in the menu.

1 Connect the external DC cable to the Vivo 65. Make sure that it is fitted correctly.

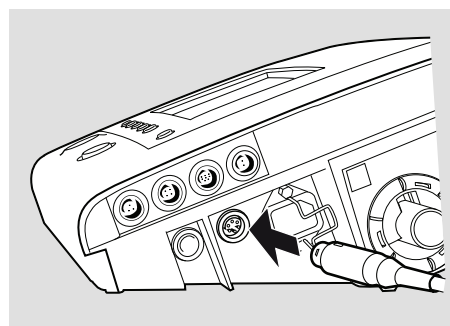

2 Connect the other end of the cable to the DC source.



The switchover to external DC can be tested by connecting the external DC source and then disconnecting the AC power cord. The Vivo 65 will automatically switch to external DC as power source. Switchover is indicated by power source LED and information message on the screen.

5.8 Using Accessories

Connecting and Disconnecting the Cables

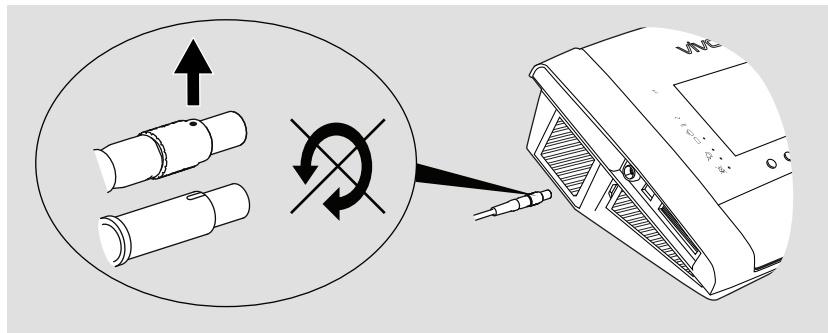

Insert the connector with the marking pointing upwards.

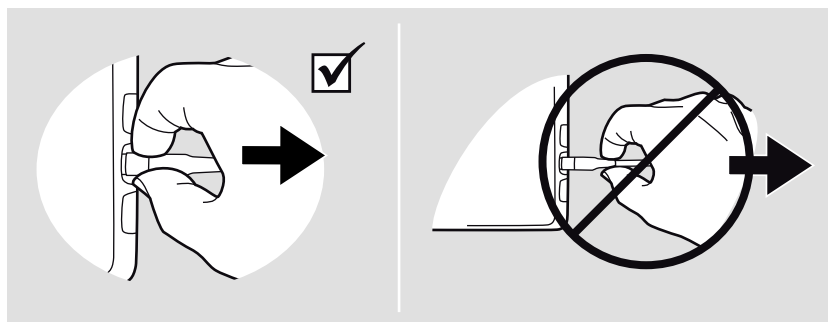

Pull the connector sleeve, not the cable itself or cable restrainer to release the connector.

Using the Vivo 65 with a Nurse Call System

The Vivo 65 can be connected to a nurse call system using the nurse call cable. When connected, the Vivo 65 alarms will also be forwarded to the nurse call system.

Connect the Vivo 65 to a Nurse Call System

- 1 Connect the nurse call cable on the left side panel of the Vivo 65.
- 2 Test the connection by triggering an alarm on the Vivo 65 and verify that the nurse call system activates.

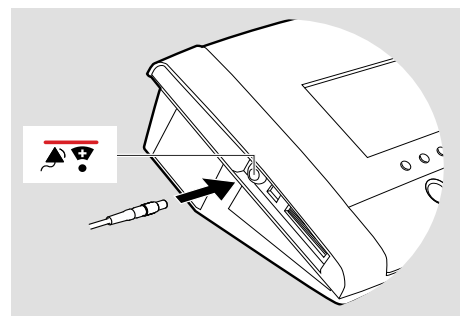

Using the Vivo 65 with the FiO₂ Sensor

The FiO₂ sensor can be connected to the Vivo 65 in order to monitor and store FiO₂ measurements. The FiO₂ sensor measures the fraction of inspired oxygen at the air outlet of the Vivo 65. The FiO₂ measurements will be stored in the data memory which can be downloaded to a PC and viewed in the Vivo 65 PC software.

The FiO₂ sensor is not intended to be in contact with the patient's body.

The FiO₂ sensor should be calibrated when first connected and then at least once a month.



FiO₂ calibration can be performed by a clinician.

How to connect the FiO₂ Sensor

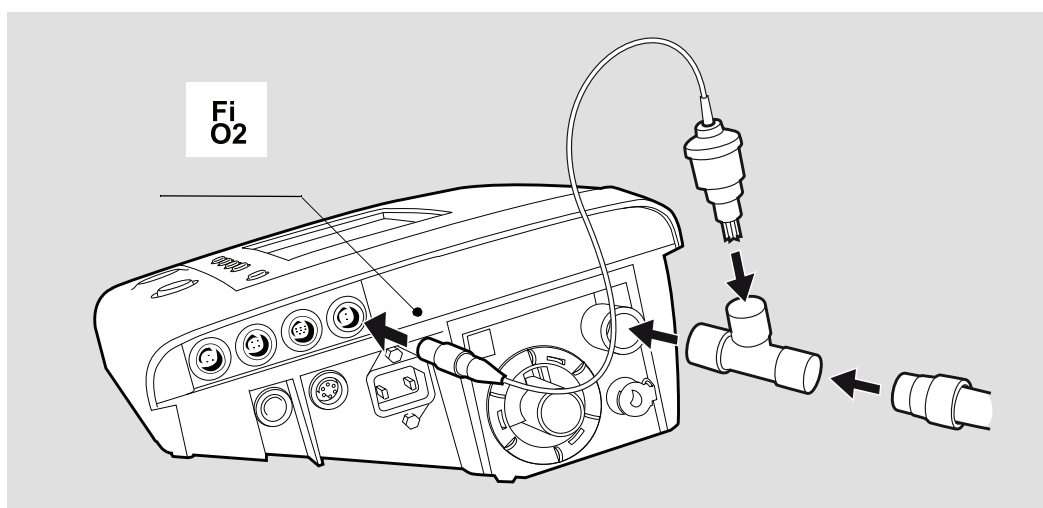

USAGE	TIME
Operating temperature	50 to 104°F (10 to 40°C)
Operating pressure	700 to 1250 mbar
Response time	<12 s
Expected operating life	<6 years (in ambient air) 1 year (in 100% O ₂)
Shelf life	6 months



Note that the operating conditions for the FiO₂ sensor are different from the Vivo 65 system conditions. If the sensor is used outside its operating conditions the FiO₂ measurements might deviate.



The FiO₂ monitoring automatically compensates for changes in ambient barometric pressure.

Cleaning

Do not clean, disinfect or autoclave the sensor, T-piece or cable.

Using the Vivo 65 with the Remote Alarm



Information about safety, warnings, product description, installation, usage, cleaning, maintenance and technical specifications can be found in the user instruction for Remote Alarm.

The Remote Alarm enables care providers and clinical personnel to monitor the Vivo 65 alarms remotely. The Remote Alarm forwards alarms from the Vivo 65. When an alarm sounds, the care provider or clinical personnel must attend to the patient quickly.

Using the Vivo 65 with the CO₂ Sensor

The CO₂ sensor can be connected to the patient breathing circuit and to a Vivo 65 in order to monitor and store CO₂ measurements. The CO₂ measurements will be stored in the Vivo 65 data memory which can be downloaded to a PC and viewed in the Vivo 65 PC software.

Safety Information



- Read this instruction thoroughly so that you completely understand how the CO₂ sensor is operated before taking it into use, to ensure correct usage and maximum performance.
- Do not use a damaged CO₂ sensor or adapter.
- The CO₂ sensor is intended to be used by authorized and trained medical personnel only.
- The CO₂ sensor is intended only as an adjunct in patient assessment. It must be used in conjunction with other assessments of clinical signs and symptoms.
- Masks' deadspace, patient's volumes and unintentional leakage may influence the CO₂ measurements.
- Disposable airway adapters shall not be reused. Reuse of the single use adapter can cause cross infection.
- Used airway adapters shall be disposed of in accordance with local regulations for medical waste.
- Measurements can be affected by mobile and RF communications equipment. It should be assured that the CO₂ sensor is used in the electromagnetic environment specified in the Vivo 65 Service Manual.
- Do not place the airway adapter between the endotracheal tube and an elbow as this may allow patient secretions to block the adapter windows and result in incorrect operation.

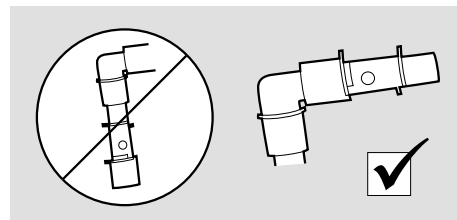

- Incorrect CO₂ zeroing will result in false gas readings.
- Replace the airway adapter if rainout/condensation occurs inside the airway adapter.
- Only use airway adapters distributed by Breas.
- Do not apply tension to the CO₂ sensor cable.
- To keep secretions and moisture from pooling on the windows, always position the CO₂ sensor in a vertical position with the green LED pointing upwards.



- If an intentional leakage port is used, make sure that the CO₂ sensor is placed between the patient interface and the leakage port.
- If a patient interface with integrated leakage is used, the monitored CO₂ values may be influenced.
- The CO₂ sensor should be placed as close to the patient interface as possible. However, a HME (Heat and Moisture Exchanger) should be placed between the patient interface and the CO₂ sensor. This will protect the airway adapter from secretions and effects of water vapour and eliminates the need of changing the airway adapter.



The CO₂ monitoring automatically compensates for changes in ambient barometric pressure.

How to Connect the CO₂ Sensor

1 Connect the CO₂ sensor cable to the CO₂ connection port on the Vivo 65 (according to the instruction “Connecting and Disconnecting the Cables” on page 101).

A green LED indicates that the CO₂ sensor is ready to use.

2 Snap the CO₂ sensor probe on top of the airway adapter. It will click into place when properly sealed.

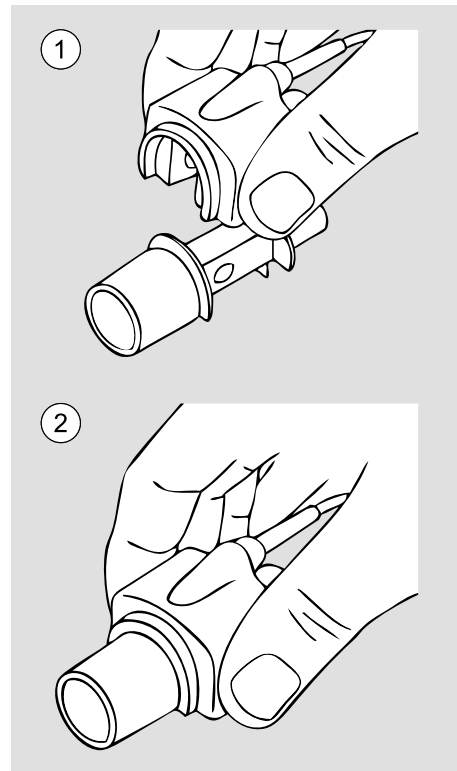

3 Perform a CO₂ zeroing procedure.

4 Connect the airway adapter to the patient circuit.

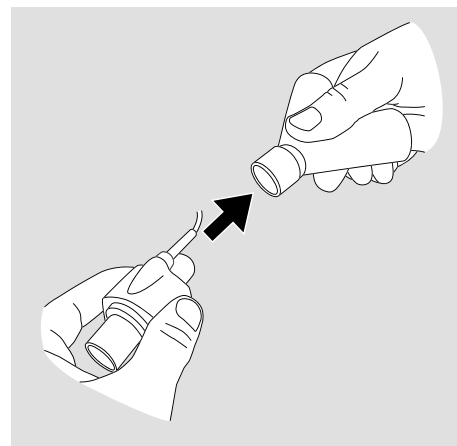

5 Make sure to position the CO₂ sensor with the LED pointing upwards.

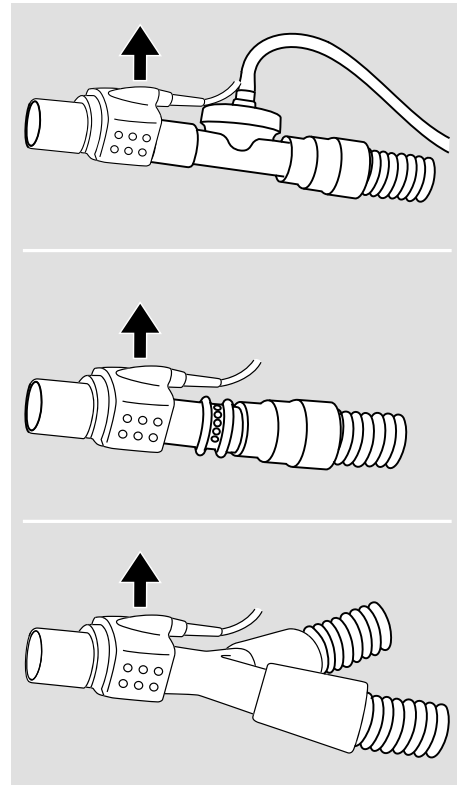

The CO₂ sensor is not intended to be in contact with the patient body.

CO₂ Zeroing

CO₂ zeroing is recommended when changing the airway adapter. Besides from that, zeroing only needs to be performed when an offset in monitored CO₂ values is observed, or when a CO₂ sensor accuracy unspecified message is displayed.



CO₂ zeroing can be performed from the “FiO₂/CO₂ Calibration” page under the “Others” section.

LED STATUS	DESCRIPTION
Steady green light	System OK
Flashing green light	Zeroing in progress
Steady red light	Sensor error
Flashing red light	Check adapter

Maintenance

No periodical maintenance is required for the CO₂ sensor.

To verify the CO₂ sensor readings, a gas span check shall be performed every year, preferably when the Vivo 65 is sent for service.



See the Vivo 65 service manual for how to perform the gas span check.



Do not under any circumstances attempt to service or repair the CO₂ sensor yourself. If you do so, the manufacturer will no longer be responsible for the performance and safety of the CO₂ sensor.

Cleaning



- Always be careful when cleaning to ensure that you do not damage any equipment.
- Fluid must not be allowed to enter into the CO₂ sensor.
- Remove the airway adapter before cleaning.
- Do not sterilize the CO₂ sensor.
- Do not autoclave the CO₂ sensor.

Clean the outside of the CO₂ sensor using a lint-free cloth moistened, but not wet, with ethanol or isopropyl alcohol (< 70%).

Disposal

The CO₂ sensor must be disposed of in accordance with the local environmental regulations regarding the disposal of used equipment and waste.

Using the Vivo 65 with the SpO₂ Module

The SpO₂ module, consisting of a SpO₂ sensor, an electronic unit and cable, is intended to measure functional oxygen saturation of arterial hemoglobin (SpO₂) and pulse rate.

The SpO₂ sensor can be connected to the Vivo 65 in order to monitor and store SpO₂ measurements. The SpO₂ measurements will be stored in the data memory which can be downloaded to a PC and viewed in the Vivo 65 PC software.

Using the Vivo 65 with the Trolley

Mount and dismount the Vivo 65 as shown in the picture:

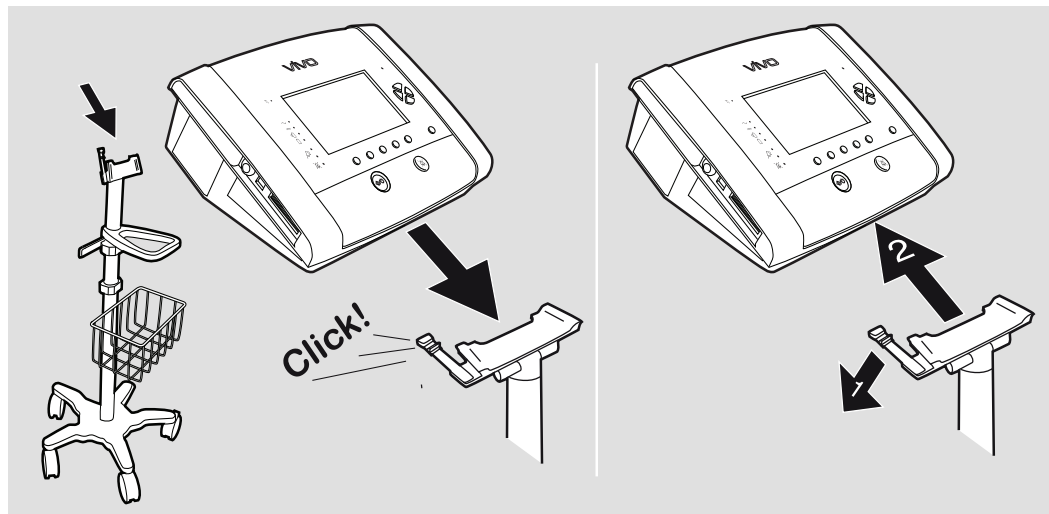

- Be careful when handling the trolley with the ventilator mounted, in order to avoid any risk of the trolley falling. The trolley can be tipped 10° and return to vertical position, when loaded in accordance with the weight specifications below.
- The total maximum load of the trolley is 52 lbs (24 kg).
- The maximum load of the trolley basket is 2 lbs (0.9 kg).

Using the Vivo 65 with the Protective Cover

The protective cover is intended for additional protection of the Vivo 65 during transportation, and in hospital, institutional and home care environments. It can be used while the Vivo 65 is operating, for example mounted on a wheelchair, in a personal vehicle, or carried by hand.

Do not use the Vivo 65 in the protective cover while positioned in a warm place, such as direct sunlight or close to a radiator.

The protective cover has the following functions:

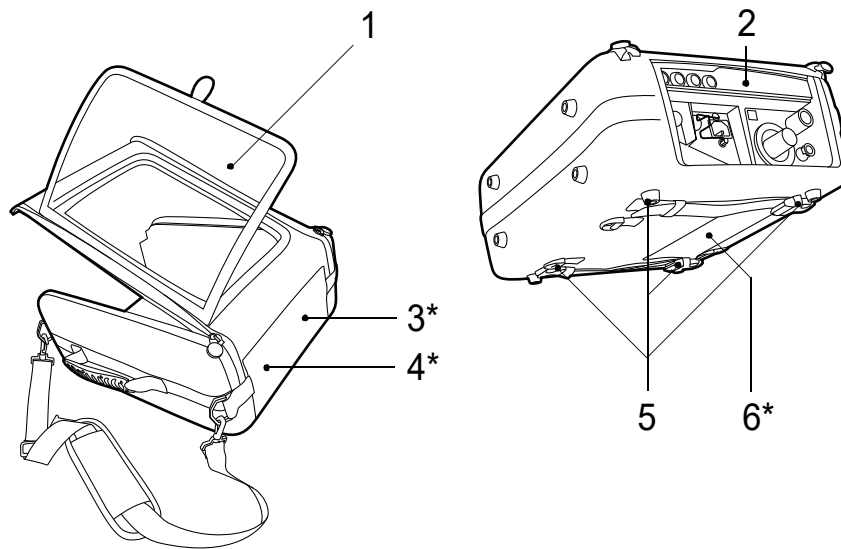

No.	COMPONENT/FUNCTION
1	Transparent window, for accessing front panel and buttons
2	Port for patient circuit, cables, O ₂ inlet, standby button
3*	Cooling air inlet
4*	Patient air inlet
5	Straps for safe mounting
6*	Cooling air outlet



* Do not cover the air inlets or outlets.

6 Alarms



The adjustable alarm settings should be re-evaluated whenever a change in settings is made on the Vivo 65.



- Never leave a patient unattended during an alarm condition.
- Setting alarm limits to extreme values could put the patient at risk.



The alarm settings are maintained during an extended power failure.

This chapter describes the alarm functions used for the Vivo 65.

The Vivo 65 remote alarm with cable provided by Breas Medical AB is the only permitted *distributed alarm system (DAS)*.

The Nurse call cable may be used for a *distributed information system for alarm conditions (DIS)*. In a DIS, the information about the alarm condition is distributed. The DIS shall not be used for making the operator aware of the existence of an alarm condition as it does not have the required functions for confirming the delivery of the alarm condition.

6.1 Alarm Function

The alarm function of the Vivo 65 consists of the alarm LEDs on the front panel, an audible alarm, and messages on the display. (See “The Vivo 65's Front Panel” on page 24 for an overview of the position of the LEDs.)

Alarm Indication



As soon as an alarm condition is detected, the Vivo 65 main unit and (if connected) the remote alarm unit will alarm without delay.

When an alarm condition arises, the alarm is indicated in three ways:

- Color LED on the panel: indicates the priority of the active alarm condition.
 - High priority: red color, flashing twice per second.
 - Medium priority: yellow color, flashing every 2 seconds.
- Alarm text in display: displays the name of the active alarm condition.

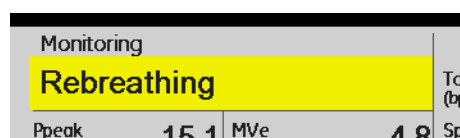
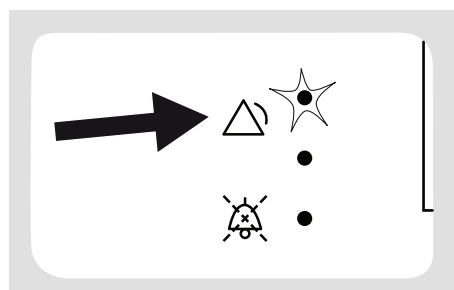

If several alarm conditions have been reached, the alarm descriptions are rolling in the display. A “>>” symbol is indicating that more than one alarm is set.

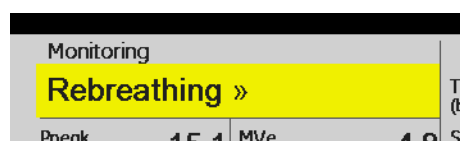

- Audible signals: indicates the priority of the active alarm condition.



- High priority: 3 signals followed by 2 more. The signal sequence is repeated with a one-half (0.5) seconds pause and thereafter a three seconds pause.



- Medium priority: 3 signals, with a lower frequency than the high priority alarm. The signal sequence repeats after a six seconds pause.



- Information: One signal with a low frequency. The signal is repeated after a five seconds pause.

- Function failure. Same signal as the high priority alarm or a constant signal, depending on the kind of function failure.

Audible Signal Pause and Reactivation

The audible signal can be paused for 60 seconds by pressing the Audio Pause button. The audible signal can be reactivated by pressing the Audio Pause button again. If a new alarm condition occurs during the audio pause period, the audible signal will be reactivated.

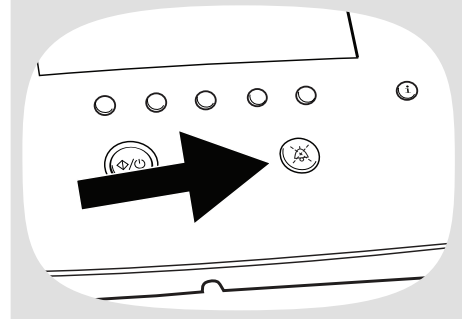

Alarm Reset

An alarm will automatically be reset once the cause of the alarm has been corrected.



If an alarm condition cannot be corrected, discontinue use and refer the Vivo 65 for service.

6.2 Operator's Position

For receiving the audible part of an alarm, the operator's position should be within audible range from the Vivo 65, depending on the set audible alarm level.

For receiving the visual part of an alarm and its priority, the operator's position should be within a distance of 13 feet (4 meters) from the Vivo 65, and within an angle of 30° to the normal of the Vivo 65 display.

6.3 Physiological Alarms

The physiological alarms of the Vivo 65 are related to the treatment parameters of the ventilator.

High Pressure Alarm

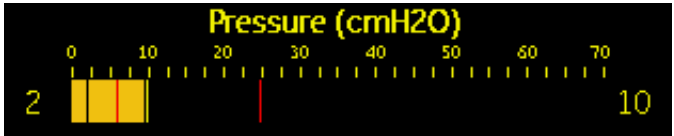
ITEM	DESCRIPTION
Definition	A High Pressure alarm will be given when the pressure reaches the set High Pressure alarm limit for 3 consecutive breaths during inspiration.
Priority	High
Possible cause	<ul style="list-style-type: none">• Mismatch between Inspiratory Pressure/CPAP and alarm setting.• Coughing during inspiration.• Changes in airway resistance and or compliance.• Blocked exhalation valve or leakage port.
Setting min	5 cmH ₂ O
Setting max	55 cmH ₂ O
Setting resolution	0.5 below 10 cmH ₂ O, 1.0 above 10 cmH ₂ O The High Pressure alarm setting is also visible with a red line in the pressure bar:
	
Ventilator action	The Vivo 65 will continue treatment with the current settings. The actual breath is however terminated if the High Pressure alarm limit is reached.

ITEM	DESCRIPTION
Indication	High Pressure The alarm is given audibly with a tone and visibly by a display message and the red alarm LED.



While sigh function is activated

- In pressure modes (during the sigh breath), the high pressure alarm will automatically be set 10 cmH₂O above set sigh pressure (max 55 cmH₂O for adult and pediatric).
- In volume modes (during the sigh breath), the high pressure alarm will automatically be increased by the same percentage as the set sigh volume percentage (max 55 cmH₂O for adult and pediatric).

Low Pressure Alarm

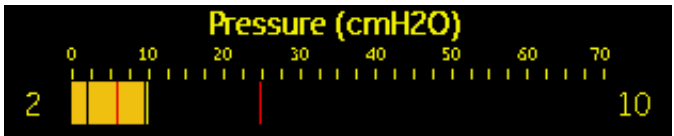
ITEM	DESCRIPTION
Definition	<p>A Low Pressure alarm will be given when the Vivo 65 pressure fails to reach the low pressure alarm limit for 15 ± 0.5 seconds.</p> <p>In MPV breath mode the alarm will be given when the pressure fails to reach the limit during inspiration.</p>
Priority	High
Possible cause	<ul style="list-style-type: none"> • Disconnection of patient circuit. • Mismatch between Inspiratory Pressure/CPAP and alarm setting. • Leakage from the mask or other components of the patient circuit.
Setting min	1 cmH ₂ O
Setting max	50 cmH ₂ O (Adult), 35 cmH ₂ O (Pediatric)
Setting resolution	<p>0.5 below 10 cmH₂O, 1.0 above 10 cmH₂O</p> <p>The Low Pressure alarm setting is also visible with a red line in the pressure bar:</p>
	
Ventilator action	The Vivo 65 will continue treatment with the same settings.
Indication	<p>Low Pressure</p>
	The alarm is given audibly with a tone and visibly by the red alarm LED and a display message.

High PEEP Alarm

ITEM	DESCRIPTION
Definition	A High PEEP alarm will be given when the measured PEEP is 30% or 2 cmH ₂ O, whichever is the greatest, above the set PEEP for more than 15 ±0.5 seconds.
Priority	Medium
Possible cause	<ul style="list-style-type: none">• Malfunction of the exhalation valve.• Too short expiratory time.• Changes in airway resistance and or compliance.• Blocked exhalation valve or leakage port.
Setting range	On, Off
Ventilator action	The Vivo 65 will continue treatment with the same settings.
Indication	High PEEP The alarm is given audibly with a tone and visibly by the yellow alarm LED and a display message.

Low PEEP Alarm

ITEM	DESCRIPTION
Definition	A Low PEEP Alarm will be given when the measured PEEP is 30% below the set PEEP for more than 60 ± 0.5 seconds.
Priority	Medium
Possible cause	<ul style="list-style-type: none">• Malfunction of the exhalation valve.• Excessive leakage.
Setting range	On, Off
Ventilator action	The Vivo 65 will continue treatment with the same settings.
Indication	 <p>The alarm is given audibly with a tone and visibly by the yellow alarm LED and a display message.</p>

High Inspired Tidal Volume Alarm (High V_{t_i})

ITEM	DESCRIPTION
Definition	A High Inspired Tidal Volume alarm will be given when the monitored Inspired Tidal Volume exceeds the set limit for the High Inspired Tidal Volume alarm for 15 ±0.5 seconds. This alarm is only used if the Vivo 65's patient circuit type is set to Exhalation valve (single limb) circuit.
Priority	Medium
Possible cause	<ul style="list-style-type: none"> • Mismatch between Inspired Tidal Volume and alarm setting. • Mismatch between selected and used patient circuit. • Pressure settings causing the Inspired Tidal Volume to exceed the set alarm level. • Leakage from the mask or other components of the patient circuit.
Setting min	300 ml (Adult), 50 ml (Pediatric)
Setting max	2500 ml, Off (Adult), 400 ml, Off (Pediatric)
Setting resolution	10 below 600 ml, 100 above 600 ml
Ventilator action	The Vivo 65 will continue treatment with the same settings.
Indication	<p>High V_{t_i}</p> <p>The alarm is given audibly with a tone and visibly by the yellow alarm LED and a display message.</p>

High Expired Tidal Volume Alarm (High V_{t_e})

ITEM	DESCRIPTION
Definition	A High Expired Tidal Volume alarm will be given when the monitored Expired Tidal Volume exceeds the set limit for the High Expired Tidal Volume alarm for 15 ± 0.5 seconds. This alarm is only used if the Vivo 65's patient circuit type is set to Dual limb or Leakage (single limb) circuit.
Priority	Medium
Possible cause	<ul style="list-style-type: none"> • Mismatch between Expired Tidal Volume and alarm setting. • Mismatch between selected and used patient circuit. • Pressure settings causing the Expired Tidal Volume to exceed the set alarm level.
Setting min	300 ml (Adult), 50 ml (Pediatric)
Setting max	2500 ml, Off (Adult), 400 ml, Off (Pediatric)
Setting resolution	10 below 600 ml, 100 above 600 ml
Ventilator action	The Vivo 65 will continue treatment with the same settings.
Indication	<p>High V_{t_e}</p> <p>The alarm is given audibly with a tone and visibly by the yellow alarm LED and a display message.</p>

Low Inspired Tidal Volume Alarm (Low V_{t_i})

ITEM	DESCRIPTION
Definition	<p>A Low Inspired Tidal Volume alarm will be given when the monitored Inspired Tidal Volume fails to reach the set limit for the Low Inspired Tidal Volume alarm for 15 ±0.5 seconds.</p> <p>This alarm is only used if the Vivo 65's patient circuit type is set to Exhalation valve (single limb) circuit.</p>
Priority	High
Possible cause	<ul style="list-style-type: none"> • Mismatch between Inspired Tidal Volume and Alarm setting. • Changes in airway resistance and or compliance. • Obstructed or occluded patient circuit.
Setting min	Off, 100 ml (Adult), Off, 20 ml (Pediatric)
Setting max	2000 ml (Adult), 300 ml (Pediatric)
Setting resolution	10 below 600 ml, 100 above 600 ml
Ventilator action	The Vivo 65 will continue treatment with the same settings.
Indication	<p>Low V_{t_i}</p> <p>The alarm is given audibly with a tone and visibly by the red alarm LED and a display message.</p>

Low Expired Tidal Volume Alarm (Low V_{t_e})

ITEM	DESCRIPTION
Definition	<p>A Low Expired Tidal Volume alarm will be given when the monitored Expired Tidal Volume fails to reach the set limit for the Low Expired Tidal Volume alarm for 15 ± 0.5 seconds.</p> <p>This alarm is only used if the Vivo 65's patient circuit type is set to Dual limb or Leakage (single limb) circuit.</p>
Priority	High
Possible cause	<ul style="list-style-type: none"> • Mismatch between Expired Tidal Volume and Alarm setting. • Changes in airway resistance and or compliance. • Obstructed or occluded patient circuit. • Leakage around the mask or within one of the components of the circuit.
Setting min	Off, 100 ml (Adult), Off, 10 ml (Pediatric)
Setting max	1500 ml (Adult), 300 ml (Pediatric)
Setting resolution	10 below 600 ml, 100 above 600 ml
Ventilator action	The Vivo 65 will continue treatment with the same settings.
Indication	<p>Low V_{t_e}</p> <p>The alarm is given audibly with a tone and visibly by the red alarm LED and a display message.</p>

High Inspired Minute Volume Alarm (High MV_i)

ITEM	DESCRIPTION
Definition	A High Inspired Minute Volume alarm will be given when the monitored inspired minute volume exceeds the set limit for the High Inspired Minute Volume alarm for 15 ±0.5 seconds. This alarm is only used if the Vivo 65's patient circuit type is set to Exhalation valve (single limb) circuit.
Priority	Medium
Possible cause	<ul style="list-style-type: none"> • Mismatch between Breath Rate, Inspired Tidal Volume settings and the alarm setting. • Increased Breath Rate. • Leakage around the mask or within one of the components of the circuit.
Setting min	1.0 l/min
Setting max	40.0 l/min, Off (Adult), 20.0 l/min, Off (Pediatric)
Setting resolution	0.5 l/min
Ventilator action	The Vivo 65 will continue treatment with the same settings.
Indication	<p>High MV_i</p> <p>The alarm is given audibly with a tone and visibly by the yellow alarm LED and a display message.</p>

High Expired Minute Volume Alarm (High MV_e)

ITEM	DESCRIPTION
Definition	A High Expired Minute Volume alarm will be given when the monitored expired minute volume exceeds the set limit for the High Expired Minute Volume alarm for 15 ±0.5 seconds. This alarm is only used if the Vivo 65's patient circuit type is set to Dual limb or Leakage (single limb) circuit.
Priority	Medium
Possible cause	<ul style="list-style-type: none">• Mismatch between Breath Rate, Tidal Volume settings and the alarm setting.• Increased Breath Rate.
Setting min	1.0 l/min
Setting max	40.0 l/min, Off (Adult), 20.0 l/min, Off (Pediatric)
Setting resolution	0.5 l/min
Ventilator action	The Vivo 65 will continue treatment with the same settings.
Indication	High MVe The alarm is given audibly with a tone and visibly by the yellow alarm LED and a display message.

Low Inspired Minute Volume Alarm (Low MV_i)

ITEM	DESCRIPTION
Definition	<p>A Low Inspired Minute Volume alarm will be given when the monitored minute volume does not reach the set limit for the Low Minute Volume alarm for 15 ± 0.5 seconds.</p> <p>This alarm is only used if the Vivo 65's patient circuit type is set to Exhalation valve (single limb) circuit.</p>
Priority	High
Possible cause	<ul style="list-style-type: none">• Mismatch between Breath Rate and Inspired Tidal Volume settings and the alarm setting.• Changes in airway resistance and or compliance.• Decreased Breath Rate.
Setting min	Off, 1.0 l/min (Adult), Off, 0.5 l/min (Pediatric)
Setting max	30.0 l/min (Adult), 10.0 l/min (Pediatric)
Setting resolution	0.5 l/min (Adult), 0.5 l/min (Pediatric)
Ventilator action	The Vivo 65 will continue treatment with the same settings.
Indication	<p>Low MV_i</p> <p>The alarm is given audibly with a tone and visibly by the red alarm LED and a display message.</p>

Low Expired Minute Volume Alarm (Low MV_e)

ITEM	DESCRIPTION
Definition	<p>A Low Expired Minute Volume alarm will be given when the monitored minute volume does not reach the set limit for the Low Minute Volume alarm for 15 ±0.5 seconds.</p> <p>This alarm is only used if the Vivo 65's patient circuit type is set to Dual limb or Leakage (single limb) circuit.</p>
Priority	High
Possible cause	<ul style="list-style-type: none"> • Mismatch between Breath Rate and Tidal Volume settings and the alarm setting. • Changes in airway resistance and or compliance. • Decreased Breath Rate. • Leakage around the mask or within one of the components of the circuit.
Setting min	Off, 1.0 l/min (Adult), Off, 0.5 l/min (Pediatric)
Setting max	30.0 l/min (Adult), 10.0 l/min (Pediatric)
Setting resolution	0.5 l/min (Adult), 0.5 l/min (Pediatric)
Ventilator action	The Vivo 65 will continue treatment with the same settings.
Indication	<div style="background-color: red; color: white; padding: 5px; text-align: center; font-weight: bold; font-size: 1.2em;">Low MVe</div> <p>The alarm is given audibly with a tone and visibly by the red alarm LED and a display message.</p>

High Breath Rate Alarm

ITEM	DESCRIPTION
Definition	A High Breath Rate alarm will be given when the delivered total breath rate exceeds the High Breath Rate alarm limit for 15 ± 0.5 seconds.
Priority	Medium
Possible cause	<ul style="list-style-type: none">• Mismatch between the Breath Rate setting and the alarm setting.• Increased Breath Rate.• Too sensitive setting of the inspiratory trigger setting.
Setting min	10 bpm
Setting max	70 bpm, Off (Adult), 99 bpm, Off (Pediatric)
Setting resolution	1 bpm
Ventilator action	The Vivo 65 will continue treatment with the same settings.
Indication	High Breath Rate The alarm is given audibly with a tone and visibly by the yellow alarm LED and a display message.

Low Breath Rate Alarm

ITEM	DESCRIPTION
Definition	A Low Breath Rate alarm will be given when the delivered total breath rate is less than the Low Breath Rate alarm limit for 15 ± 0.5 seconds.
Priority	High
Possible cause	<ul style="list-style-type: none">• Mismatch between the Breath Rate setting and the alarm setting.• The patient cannot trigger breaths because the inspiratory trigger setting is too high.• Decrease in the patient's spontaneous breathing.• Circuit disconnection.
Setting min	Off, 4 bpm (Adult), Off, 6 bpm (Pediatric)
Setting max	30 bpm (Adult), 50 bpm (Pediatric)
Setting resolution	1 bpm
Ventilator action	The Vivo 65 will continue treatment with the same settings.
Indication	Low Breath Rate The alarm is given audibly with a tone and visibly by the red alarm LED and a display message.

Apnea Alarm

ITEM	DESCRIPTION
Definition	An Apnea alarm will be given when no patient-triggered breath is detected for the set period of time.
Priority	High
Possible cause	<ul style="list-style-type: none">• Inspiratory Trigger is set too high.• Patient stopped breathing.• Patient decreases spontaneous breathing.• Circuit disconnection.
Setting min	Off, 5 s Off, 15 s (MPV breath mode)
Setting max	60 s 900 s (MPV breath mode)
Setting resolution	5 s below 15 s, 15 s above 15 s. In MPV breath mode: 15 s below 60 s, 60 s above 60 s.
Ventilator action	The Vivo 65 will continue treatment with the same settings.
Indication	<div style="background-color: red; color: white; padding: 5px; text-align: center;">Apnea</div> <p>The alarm is given audibly with a tone and visibly by the red alarm LED and a display message.</p>

Disconnection Alarm

ITEM	DESCRIPTION
Definition	<p>A Disconnection alarm will be given when the measured flow exceeds the expected leakage flow at the set Pressure.</p> <p>This alarm is not available in MPV breath mode.</p> <p> No single alarm can reliably detect all disconnections due to the number of possible combinations of therapy settings, circuit configurations and patient interfaces. However, the Low Pressure Alarm will also sound in the case of a disconnection when the alarm threshold is set at or above the PEEP pressure.</p>
Priority	High
Possible cause	<ul style="list-style-type: none">• Too high leakage in the patient circuit.• The patient has removed the mask.• Patient circuit is disconnected.
Setting range	On, Off
Ventilator action	The Vivo 65 will continue treatment with the same settings.
Indication	<p>Disconnection</p> <p>The alarm is given audibly with a tone and visibly by the red alarm LED and a display message.</p>

Rebreathing Alarm

ITEM	DESCRIPTION
Definition	<ul style="list-style-type: none">Using a leakage circuit: A Rebreathing alarm will be given when the measured leakage is lower than the expected leakage flow at the set pressure for more than 15 ± 0.5 seconds.Using an exhalation valve circuit: A Rebreathing alarm will be given if the exhalation valve is obstructed for more than 10 consecutive breaths.Using MPV breath mode: A Rebreathing alarm will be given if air returns into the Vivo 65 for more than 10 consecutive breaths.
Priority	Medium
Possible cause	<ul style="list-style-type: none">Incorrect patient circuit.Obstructed or occluded patient circuit.Patient exhales through mouthpiece.
Setting range	On, Off
Ventilator action	The Vivo 65 will continue treatment with the same settings.
Indication	<p>Rebreathing</p> <p>The alarm is given audibly with a tone and visibly by the yellow alarm LED and a display message.</p>

Obstruction Alarm

ITEM	DESCRIPTION
Definition	An obstruction alarm will be given if the inspiratory breathing tube becomes blocked and remains blocked for 2 consecutive breaths.  An obstruction of the expiratory breathing tube can be detected with the Low V_{t_e} alarm.
Priority	High
Setting range	High, Low, Off
Ventilator action	With each breath, upon detection of an obstruction, the Vivo 65 will reduce the airway pressure to the set PEEP. Treatment will resume with the start of the next breath.
Indication	Obstruction The alarm is given audibly with a tone and visibly by the red alarm LED. Indication of the alarm condition will be maintained as long as the obstruction persists.

High FiO₂ Alarm

ITEM	DESCRIPTION
Definition	A High FiO ₂ alarm will be given when the measured FiO ₂ exceeds the alarm limit for 30 ±0.5 seconds.
Priority	Medium
Possible cause	<ul style="list-style-type: none">• Increased oxygen inflow.• Decreased minute ventilation.
Setting min	21%
Setting max	100%, Off
Setting resolution	1%
Ventilator action	The Vivo 65 will continue treatment with the same settings.
Indication	High FiO₂ The alarm is given audibly with a tone and visibly by the yellow alarm LED and a display message.

Low FiO₂ Alarm

ITEM	DESCRIPTION
Definition	A Low FiO ₂ alarm will be given when the measured FiO ₂ is below the alarm limit for 30 ±0.5 seconds.
Priority	High
Possible cause	<ul style="list-style-type: none">• Decreased oxygen inlet.• Disconnection of oxygen inlet.• Increased minute ventilation.• High leakage.
Setting min	Off, 21%
Setting max	100%
Setting resolution	1%
Ventilator action	The Vivo 65 will continue treatment with the same settings.
Indication	<div style="background-color: red; color: black; padding: 5px; display: inline-block;">Low FiO₂</div> <p>The alarm is given audibly with a tone and visibly by the red alarm LED and a display message.</p>

High SpO₂ Alarm

ITEM	DESCRIPTION
Definition	A High SpO ₂ alarm will be given when the measured SpO ₂ exceeds the alarm limit for 30 seconds.
Priority	Medium
Possible cause	FiO ₂ is set too high.
Setting min	90%
Setting max	100%, Off
Setting resolution	1%
Ventilator action	The Vivo 65 will continue treatment with the same settings.
Indication	High SpO₂ The alarm is given audibly with a tone and visibly by the yellow alarm LED and a display message.

Low SpO₂ Alarm

ITEM	DESCRIPTION
Definition	A Low SpO ₂ alarm will be given when the measured SpO ₂ is below the alarm limit for 30 seconds.
Priority	High
Possible cause	<ul style="list-style-type: none">• FiO₂ is set too low.• Oxygen inlet is disconnected.• Delivered tidal volumes are too small.
Setting min	85%
Setting max	100%
Setting resolution	1%
Ventilator action	The Vivo 65 will continue treatment with the same settings.
Indication	<div style="background-color: red; color: black; padding: 5px; display: inline-block;">Low SpO₂</div> <p>The alarm is given audibly with a tone and visibly by the red alarm LED and a display message.</p>

High EtCO₂ Alarm

ITEM	DESCRIPTION
Definition	A High EtCO ₂ alarm will be given when the measured EtCO ₂ exceeds the alarm limit for 30 seconds.
Priority	High
Possible cause	<ul style="list-style-type: none">• High EtCO₂ is set too low.• Breath Rate is too low.• Delivered Tidal Volume is too low.• Excessive dead space between patient and exhalation valve/leakage port.• Exhalation port/valve is occluded.
Setting min	1 mmHg
Setting max	74 mmHg, Off
Setting resolution	1 mmHg
Ventilator action	The Vivo 65 will continue treatment with the same settings.
Indication	High EtCO₂ The alarm is given audibly with a tone and visibly by the red alarm LED and a display message.

Low EtCO₂ Alarm

ITEM	DESCRIPTION
Definition	A Low EtCO ₂ alarm will be given when the measured EtCO ₂ is below the alarm limit for 30 seconds.
Priority	Medium
Possible cause	<ul style="list-style-type: none"> • Low EtCO₂ is set too high. • Ventilator disconnection. • Excessive leakage in the Patient circuit/Interface. • Partial obstruction of the airways. • Breath Rate too high. • Delivered Tidal Volume too high. • Self triggering of the ventilator.
Setting min	Off, 1 mmHg
Setting max	74 mmHg
Setting resolution	1 mmHg
Ventilator action	The Vivo 65 will continue treatment with the same settings.
Indication	<p>Low EtCO₂</p> <p>The alarm is given audibly with a tone and visibly by the yellow alarm LED and a display message.</p>

High Inspired CO₂ Alarm (High InspCO₂)

ITEM	DESCRIPTION
Definition	A High Inspired CO ₂ alarm will be given when the measured inspired CO ₂ exceeds the alarm limit for 30 seconds.
Priority	High
Possible cause	<ul style="list-style-type: none">• High InspCO₂ is set too low.• Excessive dead space between patient and exhalation valve/leakage port.• Exhalation port/valve occluded.
Setting min	1 mmHg
Setting max	74 mmHg, Off
Setting resolution	1 mmHg
Ventilator action	The Vivo 65 will continue treatment with the same settings.
Indication	High InspCO₂ The alarm is given audibly with a tone and visibly by the red alarm LED and a display message.

High Pulse Rate Alarm

ITEM	DESCRIPTION
Definition	A High Pulse Rate alarm will be given when the measured pulse rate exceeds the alarm limit for 15 seconds.
Priority	Medium
Possible cause	<ul style="list-style-type: none">• Insufficient ventilatory support.• FiO₂ too low.• PEEP too high.
Setting min	20 bpm
Setting max	250 bpm, Off
Setting resolution	5 bpm
Ventilator action	The Vivo 65 will continue treatment with the same settings.
Indication	High Pulse Rate The alarm is given audibly with a tone and visibly by the yellow alarm LED and a display message.

Low Pulse Rate Alarm

ITEM	DESCRIPTION
Definition	A Low Pulse Rate alarm will be given when the measured pulse rate is below the alarm limit for 15 seconds.
Priority	High
Possible cause	<ul style="list-style-type: none">• Bad positioning of the finger probe• Insufficient ventilatory support• FiO₂ is low
Setting min	Off, 20 bpm
Setting max	250 bpm
Setting resolution	5 bpm
Ventilator action	The Vivo 65 will continue treatment with the same settings.
Indication	<div style="background-color: red; color: white; padding: 5px; text-align: center;">Low Pulse Rate</div> <p>The alarm is given audibly with a tone and visibly by the red alarm LED and a display message.</p>

6.4 Technical Alarms

Power Failure Alarm

ITEM	DESCRIPTION
Definition	A Power Failure alarm will be given when the last power source is below limits.
Priority	High
Ventilator action	The Vivo 65 stops treatment and gives alarm for at least 2 minutes and up to 10 minutes. If power is restored within 2 to 10 minutes, the Vivo 65 will automatically resume treatment with current settings.
Indication	The alarm is given audibly with a tone and visibly by the red alarm LED.

High Patient Air Temperature Alarm (High Patient Air Temp)

ITEM	DESCRIPTION
Definition	A High Patient Air Temperature alarm will be given when the patient air temperature exceeds 104°F (40°C).
Priority	Medium
Possible cause	<ul style="list-style-type: none">• Blocked patient air inlet.• Blocked cooling air outlets.• Too high ambient temperature.
Ventilator action	The Vivo 65 will continue treatment with the same settings.
Indication	High Patient Air Temp <p>The alarm is given audibly with a tone and visibly by the yellow alarm LED and a display message.</p>

High Internal Temperature Alarm (High Internal Temp)

ITEM	DESCRIPTION
Definition	A High Internal Temperature alarm will be given when the internal temperature is very high.
Priority	High
Possible cause	<ul style="list-style-type: none">• Blocked cooling air inlet.• Blocked cooling air outlets.• Too high ambient temperature.
Ventilator action	The Vivo 65 will continue treatment with the same settings.
Indication	High Internal Temp <p>The alarm is given audibly with a tone and visibly by the red alarm LED and a display message.</p>

Low Last Power Source Alarm

ITEM	DESCRIPTION
Definition	A Low Last Power Source alarm will be given when the last battery source (internal battery or click-on battery) has 15 minutes of operating time left with current settings.
Priority	Medium
Ventilator action	The Vivo 65 will continue treatment with the same settings.
Indication	Low Last Power Source The alarm is given audibly with a tone and visibly by the yellow alarm LED and a display message.

Lost Mains Power Alarm

ITEM	DESCRIPTION
Definition	A Lost Mains Power alarm will be given when the mains power is disconnected or lost.
Priority	Medium
Ventilator action	The Vivo 65 will continue treatment with the same settings, and switch to next available power source (external DC, click-on battery or internal battery)
Indication	Lost Mains Power The alarm is given audibly with a tone and visibly by the yellow alarm LED and a display message.

Critical Low Last Power Source Alarm

ITEM	DESCRIPTION
Definition	A Critical Low Last Power Source alarm will be given when the last battery source (internal battery or click-on battery) has at least 5 minutes of operating time left with current settings.
Priority	High
Ventilator action	The Vivo 65 will continue treatment with the same settings.
Indication	Critical Low Power Source The alarm is given audibly with a tone and visibly by the red alarm LED and a display message.

Circuit Type/Insert Mismatch Alarm

ITEM	DESCRIPTION
Definition	A Circuit Type/Insert Mismatch alarm will be given when the Vivo 65 detects an incorrect combination of the selected patient circuit type setting and the insert attached to the ventilator.
Priority	Medium
Possible cause	The Vivo 65 is set to one of the following incorrect combinations: <ul style="list-style-type: none">• Patient circuit type: Dual limb circuit / Single limb insert• Patient circuit type: Exhalation valve (single limb) circuit / Dual limb insert
Ventilator action	The Vivo 65 will continue the treatment with the same settings.
Indication	Circ./Insert Mismatch The alarm is given audibly with a tone and visible by the yellow alarm LED and a display message.

Patient Mode/Insert Mismatch Alarm

ITEM	DESCRIPTION
Definition	A Patient Mode/Insert Mismatch alarm will be given when the Vivo 65 detects an incorrect combination of the selected patient mode setting and the insert attached to the ventilator.
Priority	Medium
Possible cause	The Vivo 65 is set to one of the following incorrect combinations: <ul style="list-style-type: none">• Adult mode / Dual limb insert Pediatric• Pediatric mode / Dual limb insert Adult
Ventilator action	The Vivo 65 will continue the treatment with the same settings.
Indication	Mode/Insert Mismatch The alarm is given audibly with a tone and visible by the yellow alarm LED and a display message.

Exhalation Valve Control Error Alarm

ITEM	DESCRIPTION
Definition	An Exhalation Valve Control Error alarm will be given when the Vivo 65 fails to control the internal /external exhalation valve.
Priority	High
Possible cause	<ul style="list-style-type: none">• Malfunction in the exhalation valve.• Internal error of the ventilator.
Indication	<p>Exhalation Valve Fail</p> <p>The alarm is given audibly with a tone and visible by the red alarm LED and a display message.</p>

Vte/MVe Accuracy Unspecified Alarm

ITEM	DESCRIPTION
Definition	<p>A Vte/MVe sensor accuracy unspecified alarm occurs when the accuracy of the Vte/MVe measurement is unreliable due to an unsuccessful automatic calibration of the sensor. The Vte/MVe readings may be out of specified tolerances.</p> <p> During this alarm, alarms for Vte/MVe/Disconnection cannot be relied upon. Other means of surveillance shall be used.</p> <p>The Vivo 65 will automatically continue sensor calibration attempts. The alarm will reset when a successful calibration is made. If the alarm persists contact your service provider. The Vivo can still be used with single limb circuit.</p>
Priority	High
Indication	<p>Vte/MVe Accuracy Unspec.</p> <p>The alarm is given audibly with a tone and visible by the red alarm LED and a display message.</p>

Vte/MVe Sensor Error Alarm

ITEM	DESCRIPTION
Definition	<p>A Vte/MVe sensor error alarm occurs when the sensor for Vte/MVe measurement fails. The Vte/MVe readings on the display are not correct.</p> <p> During this alarm, alarms for high/low Vte/MVe/Disconnection cannot be relied upon. Other means of surveillance shall be used.</p> <p>Contact your service provider. The Vivo 65 can still be used with single limb circuit.</p>
Priority	High
Indication	<p>Vte/MVe Sensor Error</p> <p>The alarm is given audibly with a tone and visible by the red alarm LED and a display message.</p>

SpO₂/CO₂/Remote Start/Stop Failure Alarm (SpO₂/CO₂ Remote Fail)

ITEM	DESCRIPTION
Definition	An SpO ₂ /CO ₂ /Remote Start/Stop Failure alarm will be given when a failure occurs with the patient interface or attached units.
Priority	Medium
Possible cause	<ul style="list-style-type: none">• Failure in the Remote start/stop unit.• Failure in the SpO₂ sensor.• Failure in the CO₂ sensor.• Internal failure in the Vivo 65.
Ventilator action	The Vivo 65 will continue treatment with the same settings.
Indication	<p>SpO₂/CO₂/Remote fail</p> <p>The alarm is given audibly with a tone and visibly by the yellow alarm LED and a display message.</p>

SpO₂ Sensor Failure/Disconnection Alarm (SpO₂ Disconnected)

ITEM	DESCRIPTION
Definition	<p>An SpO₂ Sensor Failure/Disconnection alarm will be given when an error signal or no signal from the SpO₂ sensor has been detected for 2 seconds.</p> <p>Check the SpO₂ sensor.</p>
Priority	High
Possible cause	<ul style="list-style-type: none">• SpO₂ Sensor disconnected.• Failure in the SpO₂ sensor.
Ventilator action	The Vivo 65 will continue treatment with the same settings.
Indication	<p>SpO₂ Disconnected</p> <p>The alarm is given audibly with a tone and visibly by the red alarm LED and a display message.</p>

SpO₂ Signal Inadequacy Alarm (SpO₂ Signal)

ITEM	DESCRIPTION
Definition	<p>An SpO₂ Signal Inadequacy alarm will be given when the SpO₂ probe is not able to perform an adequate measurement, due to low perfusion or artefacts.</p> <p>Check the SpO₂ sensor.</p>
Priority	High
Possible cause	<ul style="list-style-type: none">• Bad positioning or occlusion of the probe.• Low blood flow in finger.
Ventilator action	The Vivo 65 will continue treatment with the same settings.
Indication	<p>SpO₂ Signal</p> <p>The alarm is given audibly with a tone and visibly by the red alarm LED and a display message.</p>

CO₂ Sensor Failure/Disconnection Alarm (CO₂ Disconnected)

ITEM	DESCRIPTION
Definition	<p>A CO₂ Sensor Failure/Disconnection alarm will be given when communication between the Vivo 65 and the CO₂ sensor has been lost.</p> <p>Check the CO₂ sensor.</p>
Priority	High
Possible cause	<ul style="list-style-type: none">• CO₂ Sensor disconnected.• Failure in the CO₂ sensor.
Ventilator action	The Vivo 65 will continue treatment with the same settings.
Indication	<p>CO2 Disconnected</p> <p>The alarm is given audibly with a tone and visibly by the red alarm LED and a display message.</p>

CO₂ Sensor Accuracy Unspecified Alarm (CO₂ Accuracy Unspec)

ITEM	DESCRIPTION
Definition	<p>A CO₂ Sensor Accuracy Unspecified alarm will be given when an unspecified accuracy in the CO₂ measurement has occurred.</p> <p>Perform a zeroing procedure of the CO₂ sensor.</p>
Priority	High
Ventilator action	The Vivo 65 will continue treatment with the same settings.
Indication	<p>CO₂ Accuracy Unspec.</p> <p>The alarm is given audibly with a tone and visibly by the red alarm LED and a display message.</p>

Check CO₂ Adapter Alarm

ITEM	DESCRIPTION
Definition	<p>A Check CO₂ Adapter alarm will be given when the airway adapter is not attached correctly to the CO₂ sensor.</p> <p>Check/replace the airway adapter.</p>
Priority	High
Ventilator action	The Vivo 65 will continue treatment with the same settings.
Indication	<p>Check CO2 adapter</p> <p>The alarm is given audibly with a tone and visibly by the red alarm LED and a display message.</p>

CO₂ Sensor Error Alarm

ITEM	DESCRIPTION
Definition	<p>A CO₂ Sensor Error alarm will be given when an error in the CO₂ sensor has occurred.</p> <p>Replace the CO₂ sensor. CO₂ monitoring cannot be performed in this condition.</p>
Priority	High
Ventilator action	The Vivo 65 will continue treatment with the same settings.
Indication	<p>CO2 Sensor Error</p> <p>The alarm is given audibly with a tone and visibly by the red alarm LED and a display message.</p>

FiO₂ Sensor Failure/Disconnection Alarm (FiO₂ Disconnected)

ITEM	DESCRIPTION
Definition	<p>An FiO₂ Sensor Failure/Disconnection alarm will be given when no signal from the FiO₂ sensor has been detected for 2 seconds.</p> <p>Check the FiO₂ sensor.</p>
Priority	High
Possible cause	<ul style="list-style-type: none">• FiO₂ Sensor disconnected.• Communication with the FiO₂ sensor failed.
Ventilator action	The Vivo 65 will continue treatment with the same settings.
Indication	<p>FiO₂ Disconnected</p> <p>The alarm is given audibly with a tone and visibly by the red alarm LED and a display message.</p>

Ambient Pressure Compensation Lost Alarm (Pressure Comp Lost)

ITEM	DESCRIPTION
Definition	<p>An Ambient Pressure Compensation Lost alarm will be given when the automatic ambient pressure compensation functionality is out of order.</p> <p>Sea level is used as temporary ambient pressure compensation. If used at other altitude, delivered and measured pressures may deviate.</p>
Priority	Medium
Ventilator action	The Vivo 65 will continue treatment with the same settings.
Indication	<p>Pressure Comp Lost</p> <p>The alarm is given audibly with a tone and visibly by the yellow alarm LED and a display message.</p>

Ambient Temperature Compensation Lost Alarm (Temperature Comp Lost)

ITEM	DESCRIPTION
Definition	An Ambient Temperature Compensation Lost alarm will be given when the automatic ambient temperature compensation is out of order.
Priority	Medium
Ventilator action	The Vivo 65 will continue treatment with the same settings. The accuracy of the volume measurement may be impaired.
Indication	Temperature Comp Lost The alarm is given audibly with a tone and visibly by the yellow alarm LED and a display message.

Humidity Compensation Lost Alarm (Humidity Comp Lost)

ITEM	DESCRIPTION
Definition	An Humidity Compensation Lost alarm will be given when the automatic humidity compensation is out of order.
Priority	Medium
Ventilator action	The Vivo 65 will continue treatment with the same settings. The accuracy of the volume measurement may be impaired.
Indication	Humidity Comp Lost The alarm is given audibly with a tone and visibly by the yellow alarm LED and a display message.

LED Failure Alarm

ITEM	DESCRIPTION
Definition	A LED Failure alarm will be given when one or more LED indicators on the front panel is broken.
Priority	Medium
Ventilator action	The Vivo 65 will continue treatment with the same settings.
Indication	LED Failure The alarm is given audibly with a tone and visibly by the yellow alarm LED, if possible, and a display message.

Alarm for Low Alarm Battery

ITEM	DESCRIPTION
Definition	An alarm for Low Alarm Battery will be given as long as the alarm battery is not charged enough. Keep the unit connected to mains until this alarm disappears.
Priority	Medium
Ventilator action	The Vivo 65 will continue treatment with the same settings.
Indication	Low Alarm Battery The alarm is given audibly with a tone and visibly by the yellow alarm LED and a display message.

Alarm for Beeper Failure

ITEM	DESCRIPTION
Definition	Failure of the beeper control by the treatment processor.
Priority	High
Ventilator action	The Vivo 65 will continue treatment with the same settings.
Indication	Alarm Beeper Fail The alarm is given audibly with a tone and visibly by the red alarm LED and a display message.

Internal Function Failure Alarms (Int. Function Failure)

ITEM	DESCRIPTION
Definition	<p>An Internal Function Failure alarm will be given when the Vivo 65 has an internal function failure.</p> <p>All Internal Function Failure alarm error codes are defined and explained in the Vivo 65 Service Manual.</p>
Ventilator action	The Vivo 65 will stop the treatment.
Indication	<p>Int. Function Failure: 34</p> <p>The alarm is given audibly with a tone and visibly by the red alarm LED and a display message for at least 2 minutes, depending on the type of alarm.</p>
Ventilator reset	In order to stop the alarm, the ventilator must be turned off by pressing the Standby button on the side panel.

6.5 Alarm Test



- In order to test an alarm it must be activated by your clinician.
- In some cases a setting must be altered.

To perform the alarm test, follow the instructions below:

Low Pressure and Disconnection Alarms

- 1 Start treatment and disconnect the patient circuit.
- 2 Wait 15 seconds.
- 3 The Low Pressure Alarm and/or the Disconnection Alarm will be given.
- 4 Stop treatment. Test completed.

Low Vti or Low Vte Alarms

- 1 Start treatment and block the patient circuit completely to simulate an occlusion.
- 2 Wait 15 seconds.
- 3 The Low Vti or Low Vte Alarm will be given.
- 4 Stop treatment. Test completed.

Obstruction Alarm

- 1 Start treatment; block the patient circuit completely to simulate an obstruction.
- 2 Wait approximately 10 seconds.
- 3 The Obstruction Alarm will be given. (If the expiratory path is blocked, a Disconnection Alarm may be triggered.)
- 4 Stop treatment. Test completed.

7 Cleaning and Maintenance



WARNING!

- The Vivo 65 should undergo maintenance, service and control procedures, as well as any applicable upgrades, in accordance with Breas service instructions.
- The Vivo 65 shall only be repaired or modified in accordance with Breas service manuals, technical bulletins, and any special service instructions, by service technicians that have been authorized after Breas Vivo 65 service training.
- Do not under any circumstances attempt to service or repair the Vivo 65 yourself. If you do so, the manufacturer will no longer be responsible for the performance and safety of the Vivo 65.

DEVIATION FROM THESE SERVICE INSTRUCTIONS MAY LEAD TO RISK OF PERSONAL INJURY!

The patient-connected parts and the filter must be cleaned and replaced regularly to ensure correct function of the Vivo 65. All replaced parts must be disposed of in accordance with local environmental regulations regarding the disposal of used equipment and waste.

7.1 Cleaning the Vivo 65



To avoid electrical shock, disconnect the power supply to the Vivo 65 before cleaning. Do not immerse the Vivo 65 into any fluids.



- Always be careful when cleaning to ensure that you do not damage any equipment.
- Fluid must not be allowed to enter the Vivo 65.
- Never apply any liquids directly on the Vivo 65 by spraying, splashing or pouring. Use a moistened lint-free cloth when cleaning.
- Do not use an excessive amount of liquid when cleaning the Vivo 65.
- Do not autoclave the Vivo 65.

Main Unit

- 1 Turn off the Vivo 65 and disconnect the power supply.
- 2 Remove the patient circuit.
- 3 Disconnect all electric cables.
- 4 Clean the outside of the Vivo 65 using a lint-free cloth and a mild soap solution. If the Vivo 65 needs to be surface disinfected, this can be done using:
 - Ethanol 70%
 - Isopropyl alcohol
 - Ethanol 90%, Methanol 9.5%, Pyridine 0.5%
- 5 Reconnect the patient circuit. Make sure all parts are dry before the Vivo 65 is put into operation.

Cooling Air Inlet Filter

The cooling air inlet filter is located in the filter cassette at the side of the ventilator. Replace the filter at least once a year. Wash the filter at least once a week.

- 1** Wash the filter using warm water and a mild soap.
- 2** Rinse thoroughly.
- 3** Dry the filter by squeezing it out in a towel. Do not wring the filter.
- 4** Make sure the filter is completely dry before inserting.

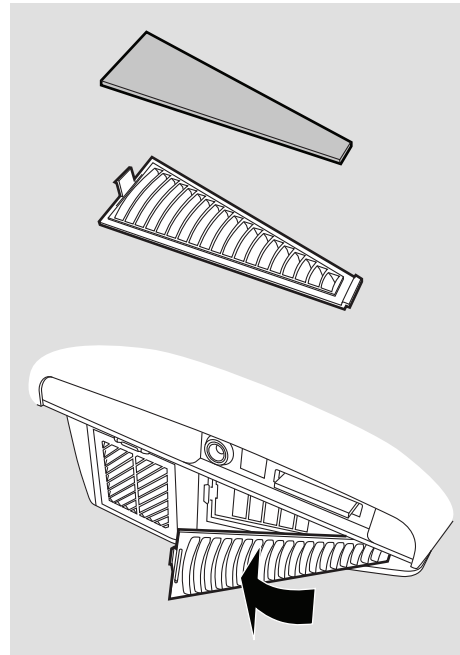

Insert

Always use a new dual insert when the ventilator is to be used by a new patient.

Check the insert regularly for damage. In case of damage, replace the insert.



Appropriate personnel should determine the duration of use for the insert based on accepted infection control procedures.

Patient Circuit



The patient circuit should be cleaned and replaced in accordance with the manufacturer's instructions and care provider's instructions, where applicable.

Always use a new patient circuit when used by a new patient.

Check the patient circuit regularly for damage. In case of damage, replace the circuit.

7.2 Cleaning and Replacing the Patient Air Filters

The patient air filters are located in the filter cassette at the side of the ventilator.

There are two types of filters:

- washable filter
- disposable filter

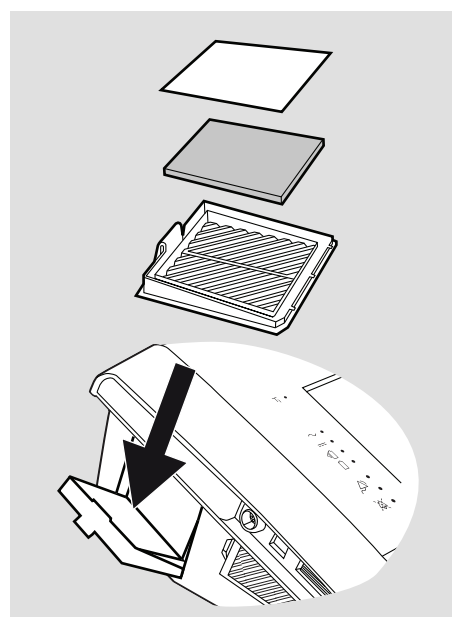

Washable Filter (grey)

Replace the washable filter at least once a year. Wash the filter at least once a week.

- 1 Wash the filter using warm water and a mild soap.

- 2 Rinse thoroughly.
- 3 Dry the filter by squeezing it out in a towel. Do not wring the filter.
- 4 Make sure the filter is completely dry before inserting.

Disposable Filter (white)

Replace the white filter at least every 4th week, or more frequently when used in high pollution or pollen-rich environments.



Do not wash or reuse the disposable filter.

7.3 Change of Patient

If the Vivo 65 is used in a clinic by several patients, a low resistant bacterial filter may be used between the air outlet and the patient tube to prevent patient cross-contamination.

- 1 Follow the instructions in “Cleaning the Vivo 65” on page 170, steps 1 to 5.
- 2 Replace the patient filters according to “Cleaning and Replacing the Patient Air Filters” on page 172.
- 3 If a low resistant bacterial filter is used, it shall be replaced.
- 4 Use a new patient circuit and a new dual insert when the Vivo 65 is used by a new patient.

7.4 Regular Maintenance Control

Regular maintenance inspections and controls shall be carried out at least every 24 months, according to the Vivo 65 Service Manual.



Do not use the device and contact your responsible care provider for an inspection of the device in the event of:

- Unexpected patient symptoms during treatment.
- Unexplainable or sudden pressure, performance or sound changes during operation.
- Suspected damage to the device, including the occurrence of Internal Functional Failure alarms.
- Suspected damage to the click-on or external battery, including evidence of battery cell leakage.

7.5 Service and Repair

The service and repair of the Vivo 65 must only be carried out by authorized service personnel in accordance with Breas service instructions. Service inspections must always be carried out following any repairs to the device.



Authorized service workshops can order the Vivo 65 Service Manual that contains all technical documentation required for the maintenance and service of the Vivo 65.

7.6 Storage

Store the Vivo 65 in a dark room, where the temperature range is within -4 to +140°F (-20 to +60°C). For instructions on how to charge the batteries after long time storage, see “Using Batteries” on page 92.



- The Vivo 65 must not be stored in a warm place, such as direct sunlight or close to a radiator.
- If stored in a cold environment, let the Vivo 65 adapt to room temperature before using the device.

7.7 Disposal

The Vivo 65, any accessories and all replaced parts must be disposed of and recycled in accordance with the local environmental regulations regarding the disposal of used equipment and waste.



Batteries used with the Vivo 65 shall be recycled in accordance with the local environmental regulations.

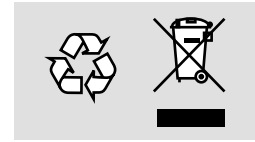

8 Technical Specifications

8.1 System Description

Dual Limb Circuit with Integrated Exhalation Valve

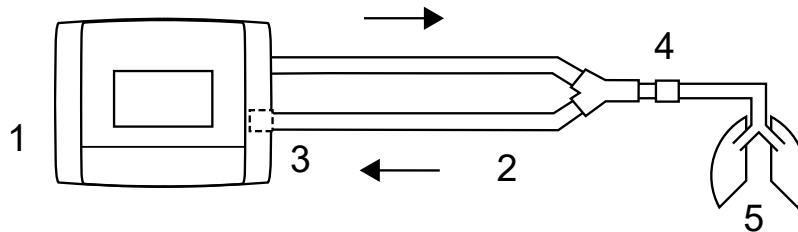

No.	DESCRIPTION
1	Vivo 65
2	Tubes
3	Insert with integrated exhalation valve
4	Patient interface connection
5	Patient

Single Limb Circuit with Active Exhalation Valve

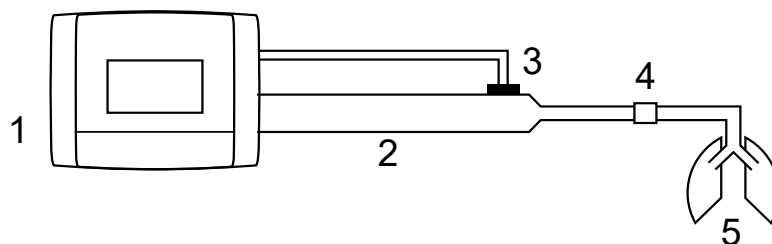

No.	DESCRIPTION
1	Vivo 65
2	Tube
3	Active Exhalation valve
4	Patient interface connection
5	Patient

Single Limb Circuit with Leakage Port

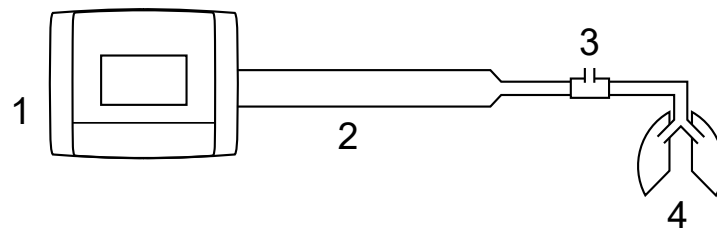

No.	DESCRIPTION
1	Vivo 65
2	Tube
3	Leakage port / Patient interface connection
4	Patient

MPV Breath Mode

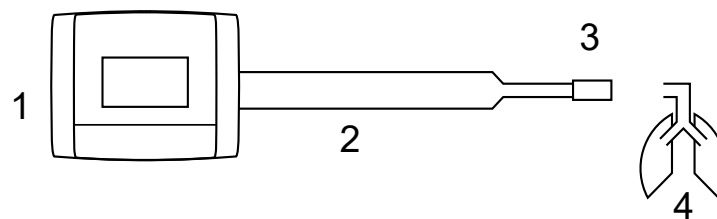

No.	DESCRIPTION
1	Vivo 65
2	Tube
3	Mouthpiece interface
4	Patient

Pneumatic Diagram for the Vivo 65 with Dual Limb Circuit

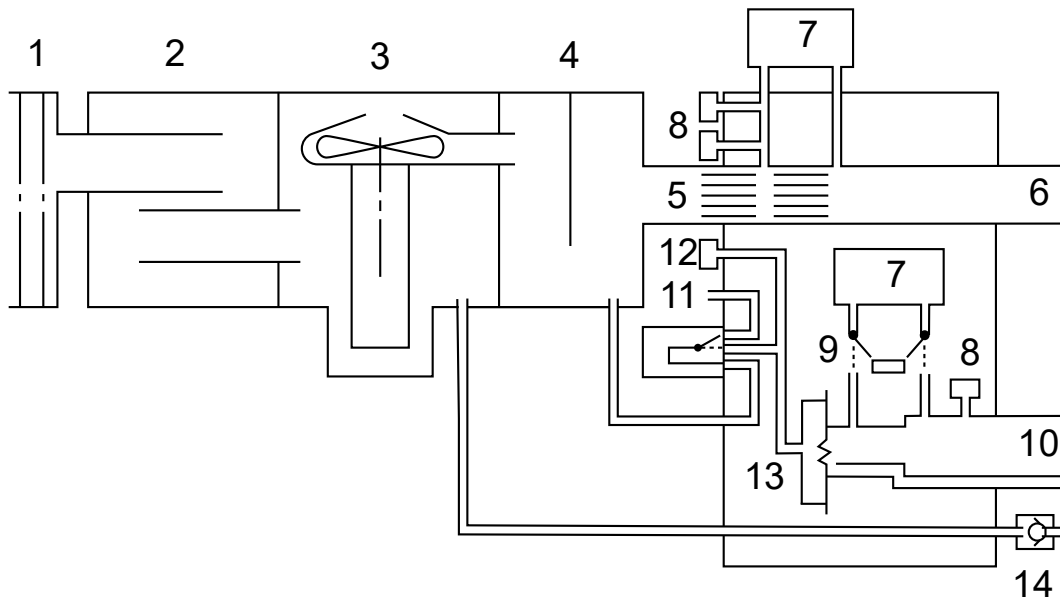

No.	DESCRIPTION
1	Air inlet with filters
2	Inlet silencer
3	Blower
4	Outlet silencer
5	Restriction
6	Patient air outlet
7	Flow sensors
8	Pressure sensors
9	Zero valve
10	Exhaled air inlet /outlet
11	Exhalation valve control pressure valve
12	Exhalation valve control pressure sensor
13	Exhalation valve
14	Low pressure/bleed-in oxygen connection

Pneumatic Diagram for the Vivo 65 with Single Limb Circuit

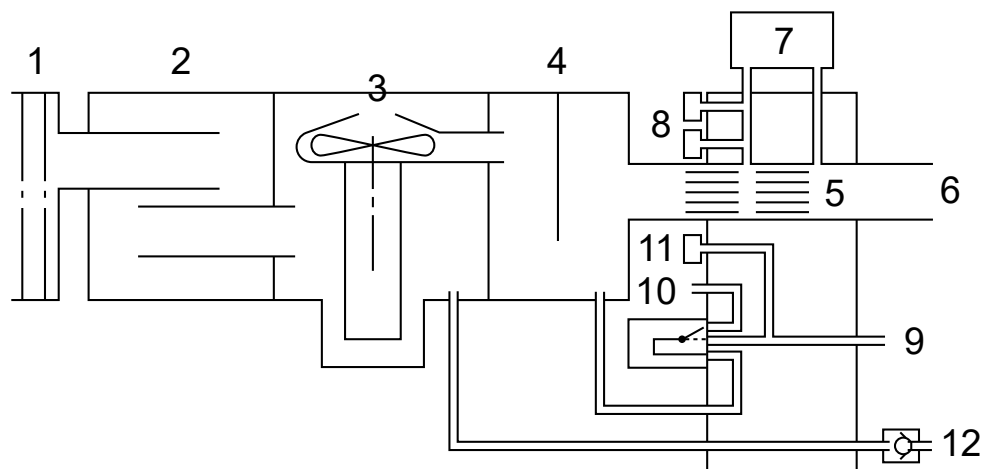

No.	DESCRIPTION
1	Air inlet with filters
2	Inlet silencer
3	Blower
4	Outlet silencer
5	Restriction
6	Patient air outlet
7	Flow sensor
8	Pressure sensors
9	Exhalation valve control pressure outlet
10	Exhalation valve control pressure valve
11	Exhalation valve control pressure sensor
12	Low pressure/bleed-in oxygen connection

Worst Case Accuracy

Pressure Control Modes

The worst case Vivo 65 System is the dual limb patient circuit with HCH humidifier, bacterial filter, FiO₂ sensor and CO₂ sensor.

Volume Control Modes

The worst case Vivo 65 System is the dual limb patient circuit with or without HCH humidifier, bacterial filter, FiO₂ sensor and CO₂ sensor.

8.2 Data Parameters

SETTING/VALUE	RANGE/PERFORMANCE	RESOLUTION
Ventilation modes	<ul style="list-style-type: none"> • PSV • PSV(TgV) • PCV • PCV(TgV) • PCV(A) • PCV(A+TgV) • PCV-SIMV • PCV-MPV • VCV • VCV(A) • VCV-SIMV • VCV-MPV • CPAP 	
Device modes	<ul style="list-style-type: none"> • Clinical • Home 	
Patient modes	<ul style="list-style-type: none"> • Adult • Pediatric 	
Inspiratory Pressure	Pediatric - 4 to 35 cmH ₂ O Adult - 4 to 50 cmH ₂ O Tolerance: ±0.5 cmH ₂ O or ±5%, whichever is greatest.	0.5 below 10 cmH ₂ O, 1.0 above 10 cmH ₂ O Note: The stated tolerances are defined relative to the set value both with or without leakage.

SETTING/VALUE	RANGE/PERFORMANCE	RESOLUTION
PEEP	Off, 2 cmH ₂ O (leakage circuit, circuit with active exhalation valve, (external/integrated), single limb exhalation valve for Pediatric VCV) to 20 cmH ₂ O (Adult), to 20 cmH ₂ O (Pediatric), Insp. Pressure -2 cmH ₂ O or Min Pressure -2 cmH ₂ O. Tolerance: ±0.5 cmH ₂ O or ±5%, whichever is greatest.	0.5 below 10 cmH ₂ O, 1.0 above 10 cmH ₂ O
Breath Rate	4 to 40 bpm (breaths per minute) (Adult), 6 to 60 bpm (Pediatric). 0 to 40/60 bpm (MPV breath mode) Tolerance: ±2%	1 bpm
SIMV Rate	4 to 40 bpm (breaths per minute) (Adult), 6 to 60 bpm (Pediatric). Tolerance: ±2%	1 bpm
Inspiratory Time	0.3 to 5 s (Adult), 0.3 to 2 s (Pediatric). Tolerance: ±0.1 s	0.1 s
Backup Inspiratory Time	0.3 to 5 s (Adult), 0.3 to 2 s (Pediatric).	0.1 s

SETTING/VALUE	RANGE/PERFORMANCE	RESOLUTION
Sigh	Sigh rate: Off, every 50 to 250 breaths. Sigh %: 200% of actual set pressure or volume. Limited to 50 cmH ₂ O or 2000 ml (Adult), 35 cmH ₂ O or 300 ml (Pediatric).	50 breaths (frequency). 25% (pressure and volume).
Rise Time	1 to 9 (PSV, PCV, PCV-SIMV, PCV-MPV, VCV-SIMV), 50% (0.3 s) to 90%, Off (VCV, VCV-SIMV, VCV-MPV).	1 (PSV & PCV), 10% (VCV)
Inspiratory Trigger	1 to 9 (PSV, PCV & VCV, PCV-SIMV, PCV-MPV, VCV-SIMV, VCV-MPV), 1 to 9, Off (PCV & VCV).	1
SIMV Support Pressure	4 to 50 cmH ₂ O (Adult), 4 to 35 cmH ₂ O (Pediatric). Tolerance: ±0.5 cmH ₂ O or ±5%, whichever is greatest.	0.5 below 10 cmH ₂ O, 1.0 above 10 cmH ₂ O
Expiratory Trigger	1 to 9.	1
Min Inspiration Time	Off, 0.3 to 3 s (Adult), Off, 0.3 to 2 s (Pediatric).	0.1 s
Max Inspiration Time	0.3 to 3 s, Off (Adult), 0.3 to 2 s, Off (Pediatric).	0.1 s
Backup Rate	4 to 40 bpm (Adult), 6 to 60 bpm (Pediatric). Tolerance: 1 bpm	1 bpm

SETTING/VALUE	RANGE/PERFORMANCE	RESOLUTION
Target Volume	Off, 300 to 2000 ml (Adult), Off, 50 to 300 ml (Pediatric). Tolerance: ±12 ml or ±10%.	10 ml below 500 ml, 50 ml above 500 ml
Max Pressure	Pediatric - Min Pressure to 35 cmH ₂ O Adult - Min Pressure to 50 cmH ₂ O	0.5 below 10 cmH ₂ O, 1.0 above 10 cmH ₂ O
Min Pressure	Pediatric - 4 cmH ₂ O to 35 cmH ₂ O or Max Pressure Adult - 4 cmH ₂ O to 50 cmH ₂ O or Max Pressure	0.5 below 10 cmH ₂ O, 1.0 above 10 cmH ₂ O
Tidal Volume	300 to 2000 ml (Adult), 50 to 300 ml (Pediatric). Tolerance: ±12 ml or ±10%.	10 ml below 500 ml, 50 ml above 500 ml
Flow Pattern	Square, Decelerating	
CPAP	4 to 20 cmH ₂ O. Tolerance: ±0.5 cmH ₂ O or ±5%, whichever is greatest.	0.5 below 10 cmH ₂ O, 1.0 above 10 cmH ₂ O
Audible alarm level	1 to 9, where 1 is the lowest volume setting and 9 is the highest volume setting.	1

MONITORED VALUE	RANGE	ACCURACY
P_{peak}	4 to 70 cmH ₂ O.	±0.5 cmH ₂ O or ±10%, whichever is greatest
PEEP	0 to 30 cmH ₂ O.	±0.5 cmH ₂ O or ±10%, whichever is greatest
P_{mean}	0 to 70 cmH ₂ O.	±0.5 cmH ₂ O or ±10%, whichever is greatest
Leakage	0 to 100 l/min (BTPS*).	±10%
MV_i	0 to 99.9 l (BTPS*).	±10% or (±10 ml × bpm), whichever is greatest
MV_e	0 to 99.9 l (BTPS*).	±10% or (±10 ml × bpm), whichever is greatest
Vt_i	0 to 9999 ml (BTPS*).	±10 ml or 10%, whichever is greatest
Vt_e	0 to 9999 ml (BTPS*).	±10 ml or (±10%, whichever is greatest)
FiO_2	0 to 100%.	±2%**
% in TgV	0 to 100%.	±1%
Total Rate	0 to 99 bpm.	1 bpm
Spont Rate	0 to 99 bpm.	1 bpm
% Spont	0 to 100%.	Not applicable
SpO_2	70 to 100%.	±3 digits. Data update period 1 s. 4-beat average signal processing.
Pulse Rate	18 to 250 bpm.	±3 digits. Data update period 1 s. 4-beat average signal processing.
I:E	1:10 to 10:1.	±0.1 unit

MONITORED VALUE	RANGE	ACCURACY
Insp. Time	0.3 to 5 s.	±0.1 s
Rise Time	0.1 to 5 s.	±10% or ±0.1 s, whichever is greatest
EtCO ₂	0 to 15%.	±(0.3 vol% + 4% of reading)
InspCO ₂	0 to 15%.	±(0.3 vol% + 4% of reading)

* BTPS (Body Temperature and Pressure Saturated)

** Effects of humidity on FiO₂ accuracy: -0.03% per % RH relative to calibration point

ALARM	SPECIFICATION	INDICATION
Auditory Alarm Signal Pressure	45 to 85 dB(A).	±5 dB(A). Measured at 1 m.
High Pressure Alarm	5 to 55 cmH ₂ O Resolution: 0.5 below 10 cmH ₂ O, 1.0 above 10 cmH ₂ O.	Red LED, audible alarm and a warning message on the display.
Low Pressure Alarm	Pediatric - 1 to 35 cmH ₂ O Adult - 1 to 50 cmH ₂ O Resolution: 0.5 below 10 cmH ₂ O, 1.0 above 10 cmH ₂ O.	Red LED, audible alarm and a warning message on the display.
High PEEP Alarm	On, Off	Yellow LED, audible alarm and a warning message on the display.
Low PEEP Alarm	On, Off	Yellow LED, audible alarm and a warning message on the display.

ALARM	SPECIFICATION	INDICATION
High V_{t_i} Alarm	150 to 2500 ml, Off (Adult), 20 to 600 ml, Off (Pediatric). Resolution: 10 below 600 ml, 100 above 600 ml.	Yellow LED, audible alarm and a warning message on the display.
High V_{t_e} Alarm	150 to 2500 ml, Off (Adult), 20 to 600 ml, Off (Pediatric). Resolution: 10 below 600 ml, 100 above 600 ml.	Yellow LED, audible alarm and a warning message on the display.
Low V_{t_i} Alarm	Off, 100 to 2000 ml (Adult) Off, 20 to 300 ml (Pediatric). Resolution: 10 below 600 ml, 100 above 600 ml.	Red LED, audible alarm and a warning message on the display.
Low V_{t_e} Alarm	Off, 100 to 2000 ml (Adult) Off, 20 to 300 ml (Pediatric). Resolution: 10 below 600 ml, 100 above 600 ml.	Red LED, audible alarm and a warning message on the display.
High MV_i Alarm	1.0 to 40.0 l, Off (Adult), 1.0 to 20.0 l, Off (Pediatric). Resolution: 0.5 l.	Yellow LED, audible alarm and a warning message on the display.
High MV_e Alarm	1.0 to 40.0 l, Off (Adult), 1.0 to 20.0 l, Off (Pediatric). Resolution: 0.5 l.	Yellow LED, audible alarm and a warning message on the display.

ALARM	SPECIFICATION	INDICATION
Low MV _i Alarm	Off, 1.0 l to 30.0 l (Adult), Off, 0.5 l to 10.0 l (Pediatric). Resolution: 0.5 l.	Red LED, audible alarm and a warning message on the display.
Low MV _e Alarm	Off, 1.0 l to 30.0 l (Adult), Off, 0.5 l to 10.0 l (Pediatric). Resolution: 0.5 l.	Red LED, audible alarm and a warning message on the display.
High Breath Rate Alarm	10 to 70 bpm, Off (Adult), 10 to 99 bpm (Pediatric). Resolution: 1 bpm.	Yellow LED, audible alarm and a warning message on the display.
Low Breath Rate Alarm	Off, 4 to 30 bpm (Adult), Off, 6 to 50 bpm (Pedi- atric). Off, 1 to 30/50 bpm (MPV breath mode) Resolution: 1 bpm.	Red LED, audible alarm and a warning message on the display.
Apnea Alarm	Off, 5 to 60 s. Resolution: 5 s below 15 s, 15 s above 15 s. In MPV breath mode: Off, 15 to 900 s Resolution: 15 s below 60 s, 60 s above 60 s.	Red LED, audible alarm and a warning message on the display.
Disconnection Alarm	On, Off	Red LED, audible alarm and a warning message on the display.
Rebreathing Alarm	On, Off	Yellow LED, audible alarm and a warning message on the display.

ALARM	SPECIFICATION	INDICATION
High FiO ₂ Alarm	21 to 100%, Off. Resolution: 1	Yellow LED, audible alarm and a warning message on the display.
Low FiO ₂ Alarm	Off, 21 to 100%. Resolution: 1	Red LED, audible alarm and a warning message on the display.
Obstruction Alarm	High, Low, Off	Red LED, audible alarm and a warning message on the display.
High SpO ₂ Alarm	90 to 100%, Off. Resolution: 1%	Yellow LED, audible alarm and a warning message on the display.
Low SpO ₂ Alarm	70 to 100%. Resolution: 1%	Red LED, audible alarm and a warning message on the display.
High EtCO ₂ Alarm	1 to 74 mmHg, Off. Resolution: 1 mmHg	Red LED, audible alarm and a warning message on the display.
Low EtCO ₂ Alarm	Off, 1 to 74 mmHg. Resolution: 1 mmHg	Yellow LED, audible alarm and a warning message on the display.
High Inspired CO ₂ Alarm	1 to 74 mmHg, Off. Resolution: 1 mmHg	Red LED, audible alarm and a warning message on the display.
High Pulse Rate Alarm	20 to 250 bpm, Off. Resolution: 5	Yellow LED, audible alarm and a warning message on the display.
Low Pulse Rate Alarm	Off, 20 to 250 bpm. Resolution: 5	Red LED, audible alarm and a warning message on the display.

ALARM	SPECIFICATION	INDICATION
Power Failure Alarm	AC: 60 to 80 V AC Ext. DC 24 V: 18 V (See the Service manual for Internal and Click-on battery specification.)	Red LED and a audible alarm.
High Patient Air Temp Alarm	Air delivered to patient may exceed 104°F (40°C).	Red LED, audible alarm and a warning message on the display.
High Internal Temperature Alarm	Internal temperature has exceed 185°F (85°C).	Red LED, audible alarm and a warning message on the display.
Low Last Power Source Alarm	The last battery source (internal battery or click-on battery) has 15 minutes of operating time left.	Yellow LED, audible alarm and a warning message on the display.
Lost Mains Power Alarm	Mains power fail, or power cord disconnected.	Yellow LED, audible alarm and a warning message on the display.
Critical Low Last Power Alarm	The last battery source (internal battery or click-on battery) has 5 minutes of operating time left.	Red LED, audible alarm and a warning message on the display.
SpO ₂ /CO ₂ /Remote Start/Stop/Failure Alarm	Failure in the Remote Start/Stop unit, SpO ₂ sensor, CO ₂ sensor, or an internal failure in the Vivo 65.	Yellow LED, audible alarm and a warning message on the display.
SpO ₂ Sensor Failure/Disconnection Alarm	Disconnection or failure of the SpO ₂ sensor.	Red LED, audible alarm and a warning message on the display.
SpO ₂ Signal Inadequacy Alarm	SpO ₂ probe unable to perform an adequate measurement, due to low perfusion or artefacts.	Red LED, audible alarm and a warning message on the display.

ALARM	SPECIFICATION	INDICATION
CO ₂ Sensor Failure/Disconnection Alarm	Disconnection or failure of the CO ₂ sensor.	Red LED, audible alarm and a warning message on the display.
CO ₂ Sensor Accuracy Unspecified Alarm	The CO ₂ measurement is inaccurate.	Red LED, audible alarm and a warning message on the display.
Check CO ₂ Adapter Alarm	The airway adapter is not attached correctly to the CO ₂ sensor.	Red LED, audible alarm and a warning message on the display.
CO ₂ Sensor Error Alarm	Error in the CO ₂ Sensor.	Red LED, audible alarm and a warning message on the display.
FiO ₂ Sensor Failure/Disconnection Alarm	No signal from the FiO ₂ sensor has been detected during 2 seconds.	Red LED, audible alarm and a warning message on the display.
Circuit Type/Insert Mismatch Alarm	Incorrect combination of patient circuit type setting and attached insert.	Yellow LED, audible alarm and a warning message on the display.
Patient Mode/Insert Mismatch Alarm	Incorrect combination of patient mode setting and attached insert.	Yellow LED, audible alarm and a warning message on the display.
Exhalation Valve Control Error Alarm	Failure to control the internal/external exhalation valve, due to malfunction of the exhalation valve or internal error of the ventilator.	Red LED, audible alarm and a warning message on the display.
Vte/MVe Accuracy Unspecified Alarm	A Vte/MVe sensor accuracy unspecified alarm occurs when the accuracy of the Vte/MVe measurement is unreliable.	Red LED, audible alarm and a warning message on the display.

ALARM	SPECIFICATION	INDICATION
Vte/MVe Sensor Error Alarm	A Vte/MVe sensor error occurs when the sensor for Vte/MVe measurement fails.	Red LED, audible alarm and a warning message on the display.
Ambient Pressure Compensation Lost Alarm	Loss of ambient pressure compensation data or ambient pressure sensor failure.	Yellow LED, audible alarm and a warning message on the display.
Ambient Temperature Compensation Lost Alarm	Loss of ambient temperature compensation data or ambient temperature sensor failure.	Yellow LED, audible alarm and a warning message on the display.
Humidity Compensation Lost Alarm	Loss of humidity compensation data or humidity sensor failure.	Yellow LED, audible alarm and a warning message on the display.
LED Failure Alarm	One or more LED indicators on the front panel are broken.	Yellow LED, audible alarm and a warning message on the display.
Alarm for Low Alarm Battery	Alarm battery voltage is below alarm limit.	Yellow LED, audible alarm and a warning message on the display.
Alarm for Beeper Failure	Failure of the beeper control by the treatment processor.	Red LED, audible alarm and a warning message on the display.
Internal Function Failure Alarms	Various types of internal function failures. For definitions, refer to Vivo 65 Service Manual.	Red LED, audible alarm and a warning message on the display.

POWER SUPPLY	SPECIFICATION
AC supply	100 to 240 V AC, tolerance: +10%/-20%, 50 to 60 Hz, max 300 VA.
External battery	24 V DC, tolerance: 24 V \pm 6 V. Max 7 A, 140 W.

POWER SUPPLY	SPECIFICATION
Click-on battery	Capacity 5.2 Ah. LiIon. Operational time 8 hours, lifetime 3 years.
Internal battery	Capacity 2.6 Ah. LiIon. Operational time 3.5 hours, lifetime 3 years.

ENVIRONMENTAL CONDITIONS	SPECIFICATION
Operating temperature range	41 to 104°F (5 to 40°C)
Storage and transport temperature	-4 to +140°F (-20 to +60°C)
Ambient pressure range	700 to 1100 mbar, corresponding to ~10000 feet (3000 meters) above sea level to ~2300 feet (700 meters) below sea level, at normal atmospheric pressure.

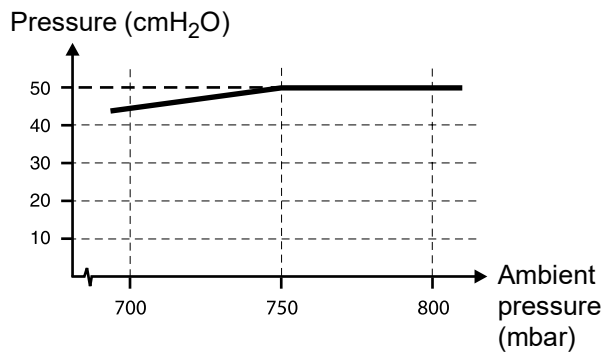

As seen in the graph above, the Vivo 65 is unable to deliver set max pressure at a very low ambient pressure.

Humidity	10% to 95%, non-condensing
----------	----------------------------

OPERATING CONDITIONS	SPECIFICATION
Recommended leakage	20 to 50 l/min at 10 cmH ₂ O (leakage circuit)
Minimum leakage	12 l/min at 4 cmH ₂ O (leakage circuit)

CIRCUIT RESISTANCE AND COMPLIANCE LIMITS	SPECIFICATION
Leakage-port circuit resistance	0 to 8 cm H ₂ O at 60 L/min (Pediatric) 0 to 20 cm H ₂ O at 120 L/min (Adult)
Leakage-port circuit compliance	0 to 4 mL/cm H ₂ O
Exhalation-valve circuit resistance	0 to 20 cm H ₂ O at 60 L/min (Pediatric) 0 to 35 cm H ₂ O at 120 L/min (Adult)
Exhalation-valve circuit compliance	0 to 4 mL/cm H ₂ O

OXYGEN INLET	SPECIFICATION
Oxygen inlet port	Maximum flow: 15 l/min (medical oxygen) Oxygen coupling is type CPC MC1602

SOUND LEVEL	SPECIFICATION
Sound level at 10 cmH ₂ O in CPAP mode	Less than 30 dB(A) Measured at 1 m

MISCELLANEOUS	RESULT & RANGE
Maximum flow	> 300 l/min
Maximum limited pressure during single fault condition	70 cmH ₂ O (PCV, PSV & VCV) 30 cmH ₂ O (CPAP)
Breathing resistance under single-fault	<6 cmH ₂ O at 30 l/min <6 cmH ₂ O at 60 l/min
Bias-flow when using active exhalation valve	5 l/min

VIVO 65 DIMENSIONS	SPECIFICATIONS
W × H × D	13.7 × 4.7 × 10.4 inch (348 × 120 × 264 mm) without click-on battery (13.7 × 4.7 × 11.4 inch (348 × 120 × 290 mm) with click-on battery)
Weight	11.7 lb (5 kg) without click-on battery (15.2 lb (7 kg) with click-on battery)
Patient air outlet	22 mm male, 15 mm female conical standard connector

CO2 SENSOR	SPECIFICATIONS
W × H × D	1.5 × 1.5 × 1.4 inch (38 × 37 × 34 mm)
Cable length	7.8 ft (2.4 m)
Weight	0.2 lb (75 g)
Warm-up time	10 s
Total system response time	<1 s
Interference from medical gases: O ₂	<-0.1% relative CO ₂ per % O ₂ (calibrated at 21% O ₂)
CO ₂ indicator	0 to 15%

Filtering/Smoothing Techniques

FUNCTION	TECHNIQUE DESCRIPTION
Pressure	Low pass average time constant 16 ms
Inspiration trigger	Differential mass flow resolution 4 ms
Expiration trigger	Flow low pass filtering with level sensing

8.3 Emission and Immunity Declaration

Vivo 65 Essential Performance

The Vivo 65 will deliver ventilation at the patient-connection port within its published accuracy specifications and within the alarm limits set by the operator, or generate an alarm condition for high pressure, low pressure, high PEEP, low inspired tidal volume, low expired tidal volume, low inspired minute volume, low breath rate, high EtCO₂, high and low FiO₂, obstruction, low last power source, or power failure.

The Vivo 65 will provide SpO₂ and pulse rate values within its published accuracy specifications and generate an alarm upon a low SpO₂ condition.

The Vivo 65 will provide indication when the SpO₂ value or pulse rate is potentially incorrect, and generate an alarm condition to indicate when the SpO₂ value update period has exceeded 30 seconds.

The Vivo 65 will provide EtCO₂ and FiO₂ values within its published accuracy specifications and generate an alarm condition upon high and low EtCO₂ and FiO₂ conditions.

Under the immunity test conditions of IEC 60601-1-2 4th Ed., the following allowances are acceptable:

- Error of delivered volume and PEEP of individual breaths up to 35% and error of the delivered volume and PEEP averaged over a one-minute interval up to 25%.
- Any temporary degradation of SpO₂, EtCO₂ or FiO₂ performance following transient immunity test exposure shall recover from any disruption within 30 seconds.

Additionally, the following shall not be allowed:

- permanent damage or unrecoverable loss of function
- changes in programmable parameters or settings
- reset to default settings
- change of operating mode
- initiation of unintended operation

Guidance and Manufacturer's Declaration – Electromagnetic Immunity

The Vivo 65 is intended for use in the electromagnetic environment specified below. The customer or the user of the Vivo 65 should assure that it is used in such an environment .

IMMUNITY TEST	COMPLIANCE LEVEL	ELECTROMAGNETIC ENVIRONMENT - GUIDANCE
Electrostatic discharge (ESD) IEC 61000-4-2	± 8 kV contact ± 15 kV air	The relative humidity should be at least 5 %.
Electrical fast transient/burst IEC 61000-4-4	± 2 kV for power supply lines ± 1 kV for input/output lines	Mains power quality should be that of a typical commercial, hospital and residential environment.
Surge IEC 61000-4-5	± 1 kV line(s) to line(s)	Mains power quality should be that of a typical commercial, hospital and residential environment.
Power frequency (50/60 Hz) magnetic field IEC 61000-4-8	30 A/m	Power frequency magnetic fields should be at levels characteristic of a typical location in a typical commercial, hospital and residential environment.
Voltage dips, short interruptions and voltage variations on power supply input lines IEC 61000-4-11	0 % UT, 0.5 cycle (multiple phase analysis); 0 % UT, 1 cycle; 70 % UT, 25/30 cycles (50/60 Hz); 0 % UT, 250/300 cycles (50/60 Hz).	Vivo 65 runs on internal battery during voltage dips, short interruptions and voltage variations on power supply input lines.

IMMUNITY TEST	COMPLIANCE LEVEL	ELECTROMAGNETIC ENVIRONMENT - GUIDANCE
Proximity Magnetic Fields IEC 61000-4-39	30 kHz: 8 A/m* 134.2 kHz: 65 A/m 13.56 MHz: 7.5 A/m * Applicable to home healthcare only.	Proximity magnetic fields should be at levels characteristic of a typical location in a typical commercial, hospital, and residential environment.

Proximity Fields for RFI

TEST FREQUENCY (MHz)	BAND ^{a)} (mhz)	SERVICE ^{a)}	MODULATION	Immunity Test Level (V/m)
385	380 - 390	Tetra 400	Pulse modulation ^{b)} 18 Hz	27
450	430 - 470	GMRS 460, FRS 460	FM ^{c)} ± 5 kHz deviation 1 kHz sine	28
710	704 - 787	LTE Band 13, 17	Pulse modulation ^{b)} 217 Hz	9
745				
780				
810	800 - 960	GSM 800/900, TETRA 800, iDEN 820, CDMA 850, LTE Band 5	Pulse modulation ^{b)} 18 Hz	28
870				
930				
1720	1700 - 1990	GSM 1800; CDMA 1900; GSM 1900; DECT; LTE Band 1, 3, 4, 25; UMTS	Pulse modulation ^{b)} 217 Hz	28
1845				
1970				
2450	2400 - 2570	Bluetooth, WLAN, 802.11 b/g/n, RFID 2450, LTE Band 7	Pulse modulation ^{b)} 217 Hz	28
5240	5100 - 5800	WLAN 802.11 a/n	Pulse modulation ^{b)} 217 Hz	9
5500				
5785				

TEST FREQUENCY (MHZ)	BAND ^{a)} (mhz)	SERVICE ^{a)}	MODULATION	Immunity Test Level (V/m)
----------------------	--------------------------	-----------------------	------------	---------------------------

If necessary to achieve the immunity test level, the distance between the transmitting antenna and the me equipment or mew system may be reduced to 1 m. The 1 m distance is permitted by IEC 61000-4-3.

- a) For some services, only the uplink frequencies are included.
- b) The carrier shall be modulated using a 50% duty cycle square wave signal.
- c) As an alternative to FM modulation, the carrier mat be pulse modulated using a 50% duty cycle square wave signal at 18 Hz. While it does not represent the actual modulation, it would be the worst case.



*U*T is the mains voltage prior to application of the test level.



Portable RF communications equipment (including peripherals such as antenna cables and external antennas) should be used no closer than 12 inches (30 cm) to any part of the Vivo 65, including cables specified by the manufacturer. Otherwise, degradation of the performance of this equipment could result.

IMMUNITY TEST	IEC 60601 TEST LEVEL	RECOMMENDED SEPARATION DISTANCE
Conducted RF IEC 61000-4-6	150 kHz to 80 MHz 3 V _{rms} ISM and amateur radio bands; 6 V _{rms}	$d=0.35*\sqrt{P}$ m at 150 kHz to 80 MHz
Radiated RF IEC 61000-4-3	10 V/m 80 MHz to 2.7 GHz	$d= 0.6*\sqrt{P}$ m at 80 MHz to 800 MHz $d= 1.2*\sqrt{P}$ m at 800 MHz to 2.5 GHz Equation description: P is the maximum output power rating of the transmitter in watts (W) according to the transmitter manufacturer and d is the recommended separation distance in metres (m). Field strengths from fixed RF transmitters, as determined by an electromagnetic site survey ^a , should be less than the compliance level in each frequency range ^b .  Interference may occur in the vicinity of equipment marked with this symbol.

Notes

- At 80 MHz and 800 MHz, the higher frequency range applies.
 - These guidelines may not apply in all situations. Electromagnetic propagation is affected by absorption and reflection from structures, objects and people.
- a) Field strengths from fixed transmitters, such as base stations for radio (cellular/cordless) telephones and land mobile radios, amateur radio, AM and FM radio broadcast and TV broadcast cannot be predicted theoretically with accuracy. To assess the electromagnetic environment due to fixed RF transmitters, an electromagnetic site survey should be considered. If the measured field strength in the location in which the Vivo 65 is used exceeds the applicable RF compliance level above, the Vivo 65 should be observed to verify normal operation. If abnormal performance

is observed, additional measures may be necessary, such as reorienting or relocating the Vivo 65.

b) Over the frequency range 150 kHz to 80 MHz, field strengths should be less than 10 V/m.

Guidance and Manufacturer's Declaration – Electromagnetic Emission

The Vivo 65 are intended for use in the electromagnetic environment specified below. The customer or the user of the Vivo 65 should assure that it is used in such an environment.

EMISSIONS TEST	COMPLIANCE	ELECTROMAGNETIC ENVIRONMENT – GUIDANCE
RF emissions CISPR 11	Group 1	The Vivo 65 use RF energy only for its internal function. Therefore, its RF emissions are very low and are not likely to cause any interference in nearby electronic equipment.
RF emissions CISPR 11	Class B	The Vivo 65 are suitable for use in all establishments, including domestic establishments and those directly connected to the public low-voltage power supply network that supplies buildings used for domestic purposes.
Harmonic emissions IEC 61000-3-2	Class A	
Voltage fluctuations/ flicker emission IEC 61000-3-3	Complies	

Recommended separation distances between portable and mobile RF communications equipment and the Vivo 65

The Vivo 65 is intended for use in an electromagnetic environment in which radiated RF disturbances are controlled. The customer or the user of the Vivo 65 can help prevent electromagnetic interference by maintaining a minimum distance between portable and mobile RF communications equipment (transmitters) and the Vivo 65 as recommended

below, according to the maximum output power of the communications equipment.

RATED MAXIMUM OUTPUT POWER OF TRANSMITTER (W)	SEPARATION DISTANCE ACCORDING TO THE FREQUENCY OF TRANSMITTER (M)		
	150 kHz to 80 MHz $d = 0.35 \cdot \sqrt{P}$ m	80 MHz to 800 MHz $d = 0.6 \cdot \sqrt{P}$ m	800 MHz to 2.5 GHz $d = 1.2 \cdot \sqrt{P}$ m
0.01	0.035	0.06	0.12
0.1	0.11	0.19	0.36
1	0.35	0.60	1.2
10	1.1	1.9	3.6
100	3.5	6.0	12

For transmitters rated at a maximum output power not listed above, the recommended separation distance d in metres (m) can be estimated using the equation applicable to the frequency of the transmitter, where P is the maximum output power rating of the transmitter in watts (W) according to the transmitter manufacturer.

Notes

- At 80 MHz and 800 MHz, the separation distance for the higher frequency range applies.
- These guidelines may not apply in all situations. Electromagnetic propagation is affected by absorption and reflection from structures, objects and people.

Recommended separation distances between external power conductors and the Vivo 65

RATED MAXIMUM CURRENT IN CONDUCTOR (A)	SEPARATION DISTANCE (M)
	50-60 Hz $d = I/2\pi H = I/188$
1	0.005
10	0.05
30	0.16

For conductors rated at a maximum current not listed above, the recommended separation distance d in metres (m) can be estimated using the equation $d = I/2\pi H$, where I is the maximum current rating of the conductor in amperes (A) according to the transmitter manufacturer; H is the Vivo 65 immunity compliance level to electromagnetic fields in the 50-60 Hz frequency span (30 A/m).

8.4 Default Settings

MODES AND FUNCTIONS	SETTING
Ventilation mode	Pressure, PCV(A)
Breath Mode	Assist/Control
Patient Mode	Adult
Profile 1	Active
Profile 2	Off
Profile 3	Off

PARAMETERS	DEFAULT VALUE
Inspiratory Pressure	15 cmH ₂ O
PEEP	5 cmH ₂ O
Breath Rate	12 bpm
SIMV Rate	12 bpm
Inspiration Time	1.5 s

PARAMETERS	DEFAULT VALUE
Rise Time (ventilation mode: pressure)	3
Inspiratory Trigger	3
SIMV Support Pressure	15 cmH ₂ O
Expiratory Trigger	3
Maximum Inspiratory Time	Off
Minimum Inspiratory Time	Off
Backup Rate	12 bpm
Backup Inspiration Time	1.5 s
Sigh	Off
Sigh Rate	100 bpm
Sigh %	125%
Target Volume	Off
Tidal Volume	400 ml
Max Pressure	15 cmH ₂ O
Min Pressure	15 cmH ₂ O
Flow Pattern	Square
CPAP	10 cmH ₂ O

ALARMS	DEFAULT VALUE
High Pressure Alarm	25 cmH ₂ O (Adult) 20 cmH ₂ O (Pediatric)
Low Pressure Alarm	10 cmH ₂ O
High PEEP Alarm	Off
Low PEEP Alarm	Off
High V _{t_i} Alarm	500 ml (Adult) 400 ml (Pediatric)
High V _{t_e} Alarm	500 ml (Adult) 400 ml (Pediatric)
Low V _{t_i} Alarm	300 ml (Adult) 100 ml (Pediatric)

ALARMS	DEFAULT VALUE
Low V_{t_e} Alarm	300 ml (Adult) 100 ml (Pediatric)
High MV_i Alarm	Off
High MV_e Alarm	Off
Low MV_i Alarm	Off
Low MV_e Alarm	Off
High Breath Rate Alarm	Off
Low Breath Rate Alarm	Off
Apnea Alarm	Off
Disconnection Alarm	On
Rebreathing Alarm	On
High FiO_2 Alarm	Off
Low FiO_2 Alarm	Off
High SpO_2 Alarm	Off
Low SpO_2 Alarm	85%
High $EtCO_2$ Alarm	51 mmHg
Low $EtCO_2$ Alarm	Off
High $InspCO_2$ Alarm	Off
High Pulse Rate Alarm	Off
Low Pulse Rate Alarm	Off
OTHERS	DEFAULT VALUE
Patient operating time	0 h
Display light	On
Light Intensity	5
Alarm sound level	5
CO_2 Unit	mmHg
Auto keypad lock	Off

OTHERS	DEFAULT VALUE
Patient circuit type	Dual limb circuit for integrated exhalation valve
Pre-use Test	On

9 Accessories

9.1 Breas Accessories List



Only use accessories recommended by Breas Medical AB. Breas Medical AB cannot guarantee the performance and safety for the use of other accessories with the Vivo 65.

To reduce the likelihood of disconnection and to prevent adverse ventilator performance, use only accessories compatible with the Vivo 65.



Accessory equipment connected to the analog and digital interfaces must be certified according to the respective IEC standards (e.g. IEC 60950 for data processing equipment and IEC 60601-1 for medical equipment). Furthermore all configurations must comply with the valid version of the system standard IEC 60601-1. Anybody who connects additional equipment to the signal input part or signal output part is configuring a medical system, and is therefore responsible for ensuring the system complies with the requirements of the valid version of the system standard IEC 60601-1. If in doubt, consult the technical service department or your local representative.

The following Breas accessories are currently available for the Vivo 65:

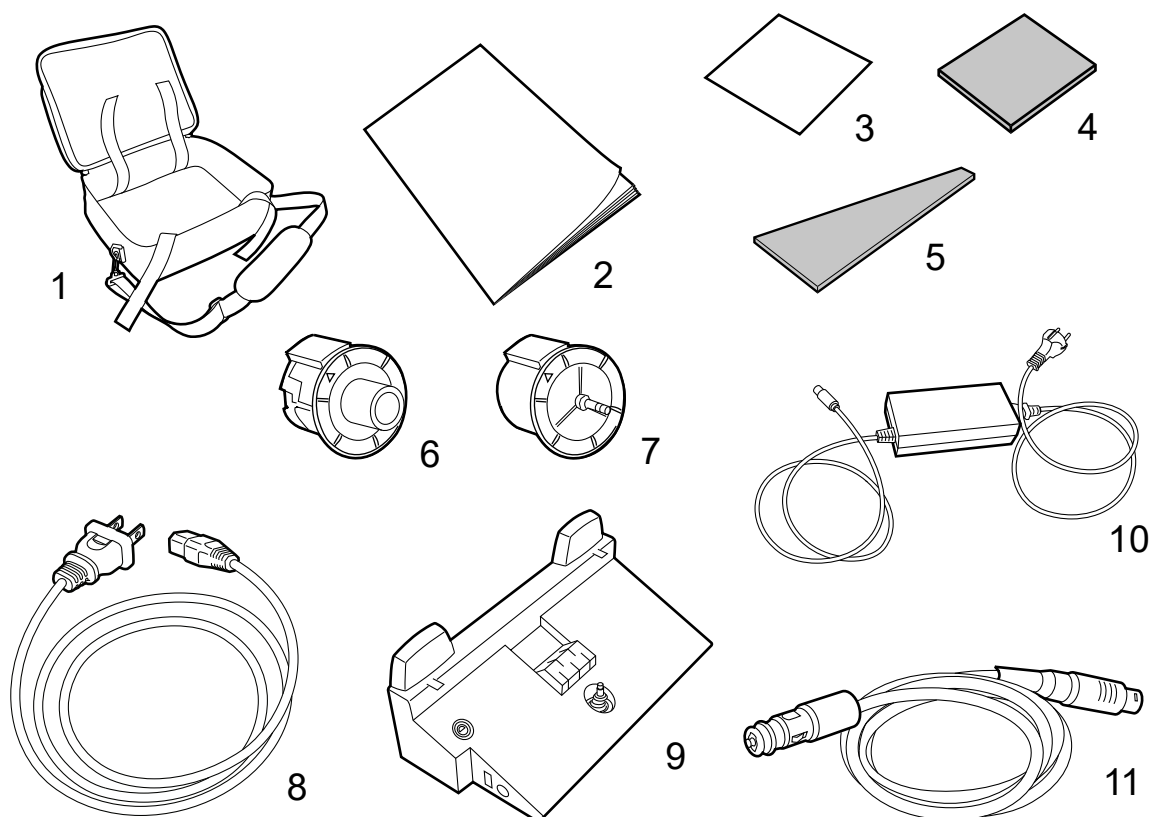

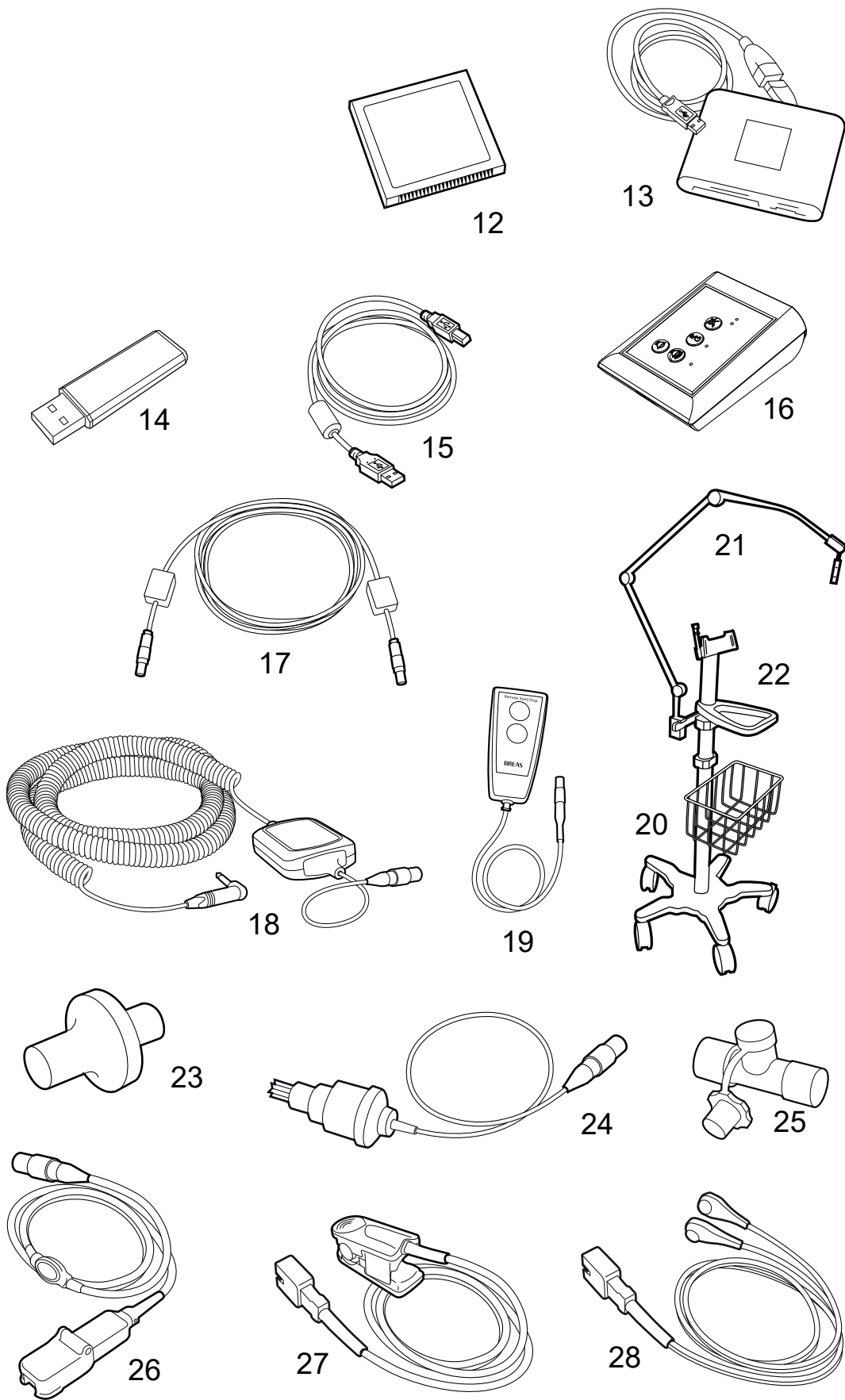

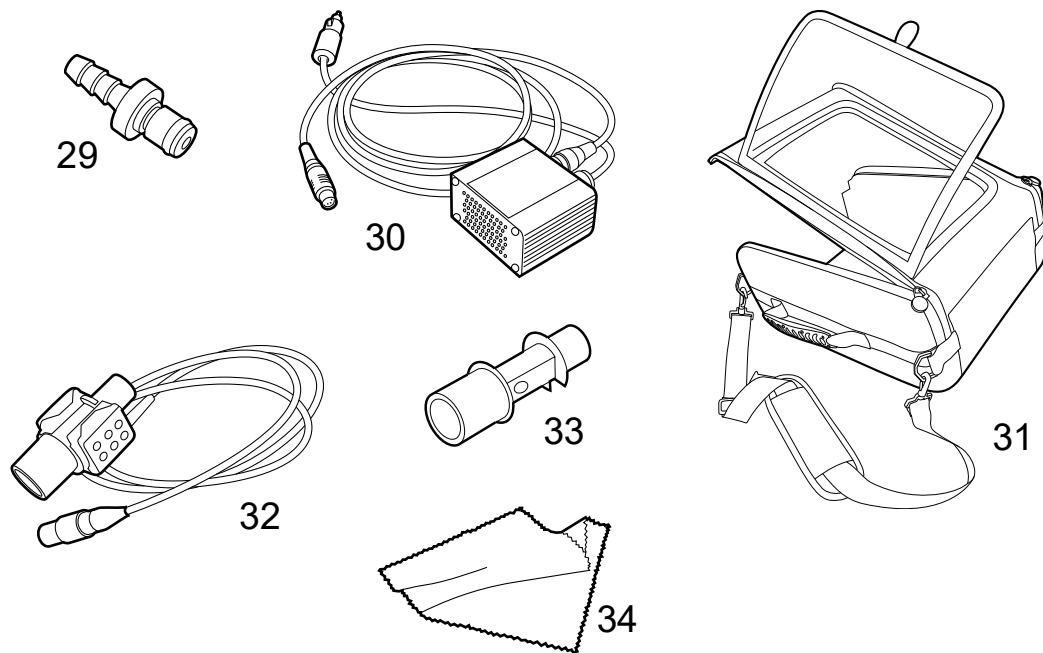

No.	COMPONENT	FUNCTION	PART NO.
1	Carry bag	Storage for transportation	006343
2	Users manual	Operating information	006088
3	Patient air inlet filter (white)	Inlet air filtration	004910 (10 pcs)
4	Patient air inlet filter (grey)	Inlet air filtration	004909 (5 pcs)
5	Cooling air inlet filter (grey)	Inlet air filtration	006435 (5 pcs)
6	Dual limb insert	Connection between ventilator and dual limb circuit, with integrated exhalation valve, for adult or pediatric use	Adult: 005523 (disposable) Pediatric: 005525 (disposable)
7	Single limb insert	Connection for ventilator and single limb circuit, with external exhalation valve connector	005521

No.	COMPONENT	FUNCTION	PART NO.
8	Power cord		1.8 m: 005432 3.6 m: 007219
9	Click-on battery	Power source for transportation	004559
10	Click-on battery charger		EU: 005186 US: 005189 UK: 005187 AU/NZ: 005188 JP: 005190
11	External Battery cable 24 V DC		004899
12	Memory card	Vivo 65 settings, patient data and usage data	003619
13	Memory card reader/writer	Read/write memory card	002185
14	Vivo 55/65 PC software USB	Data monitoring software	005928
15	USB cable	Data cable: PC and Vivo 65 (USB to USB)	004886
16	Remote alarm with cable	Monitor Vivo 65 alarms remotely	10 m: 006348 25 m: 006349
17	Remote alarm cable		10 m: 006359 25 m: 006360 50 m: 006361

No.	COMPONENT	FUNCTION	PART NO.
18	Nurse call cable	Connect the Vivo 65 to a hospital nurse call system	NO: 006365 NC: 006364 10 kohm, NO: 006363 10 kohm, NC: 006362
19	Remote start/stop	Start and stop the Vivo 65 remotely	006342
20	Trolley	Transportation	005051
21	Patient circuit arm		005031
22	Mounting bracket	Mount the Vivo 65 on the trolley or a hospital rail system	005122
23	Low resistant bacterial filter (007963
24	FiO ₂ sensor	Measure O ₂ in the patient air	006347
25	T-piece with plug	Connect the FiO ₂ sensor to the patient circuit	005990
26	SpO ₂ module	Connection cable	006369
27	SpO ₂ sensor	Finger Clip SpO ₂ sensor	adult: 006589 pediatric: 006590
28	SpO ₂ sensor	Multisite SpO ₂ sensor	006591
29	Low pressure oxygen adapter		005032
30	12/24 V converter		004901
31	Protective cover	Shock protection	006344
32	CO ₂ sensor	Measure CO ₂ in the patient air	006346
33	Airway adapter, disposable	Connects the CO ₂ sensor to the patient circuit	005263 (25 pcs)

No.	COMPONENT	FUNCTION	PART NO.
34	Polishing cloth		005066

10 Patient Settings

This page can be copied and used for noting the patient's settings.

Patient Settings - Breas Vivo 65

Patient
Date
Clinic
Set by

PCV PSV VCV MPV CPAP

Patient Circuit
Pressure Inspiratory Trigger
PEEP Expiratory Trigger
Breath Rate Min Inspiratory Time
Inspiratory Time..... Max Inspiratory Time.....
Backup Rate Backup Inspiratory Time.....
Target Volume..... Min Pressure
Tidal Volume..... Max Pressure
Flow Pattern..... CPAP
SIMV Rate SIMV Support Pressure.....

Notes
.....
.....
.....
.....

11 FAA Compliance

To whom it may concern:

The US Department of Transportation (DOT) Final Rule, “Nondiscrimination on the Basis of Disability in Air Travel” (73 FR 27614 which updates Title 14 CFR Part 382), effective May 13, 2009 provides important requirements for the accommodation of passengers with respiratory assistive devices (Ventilators, Respirators and CPAP machines).

In line with these requirements, respiratory assistive devices may be used onboard an aircraft, without further testing by the carrier, provided they have been tested for Electromagnetic Compatibility (EMC) in accordance with the current version of RTCA/DO-160, Section 21, Category M.

Breas Medical has successfully completed testing for the Vivo 65 System. The Vivo 65 System complies with RTCA/DO-160, Section 21, Category M and can be considered FAA compliant.

Some airlines may require advance notification before travel, and devices may need to be operated by battery. Breas Medical recommends that customers check with their airline.

12 Index

Symbols

% in TgV	
monitored value	56
% Spont breaths	
monitored value	57
+/- buttons	24

A

AC power	
connect Vivo	34
AC power inlet	
position	26
Accessories	207
usage	101
Adjust	
patient settings	41
Adult	
circuit type	35
insert	35
Adult mode	82
Air inlet, position	25
Air travel	214
Alarm	111
indication	112
reset	113
Technical	142
Alarm section	51
Alarm sound level	53
Alarm test	132
Obstruction Alarm	168
Alarm/Event History	51
Alarms	
Ambient Pressure Compensation Lost	161
Ambient Temperature Compensation Lost	162
Apnea	129
Check CO2 Adapter	158
Circuit Type/Insert Mismatch	148
CO2 Sensor Accuracy Unspecified	157
CO2 Sensor Error	159
CO2 Sensor Failure/Disconnection	156
delivery settings	204
Disconnection	130
Exhalation Valve Control Error	150
FiO2 Failure/Disconnection	160
High Breath Rate	127
High EtCO2	137
High Expired Minute Volume	124
High Expired Tidal Volume	120

High FiO2	133
High InspCO2	139
High Inspired Minute Volume	123
High Inspired Tidal Volume	119
High Patient Air Temperature	143
High PEEP	117
High Pressure	114
High Pulse Rate	140
High SpO2	135
Humidity Compensation Lost	163
Internal Function Failure	167
LED Failure	164
Low Alarm Battery	165, 166
Low Breath Rate	128
Low EtCO2	138
Low Expired Minute Volume	126
Low Expired Tidal Volume	122
Low FiO2	134
Low Inspired Minute Volume	125
Low Inspired Tidal Volume	121
Low Last Power Source	145, 146, 147
Low PEEP	118
Low Pressure	116
Low Pulse Rate	141
Low SpO2	136
Patient Mode/Insert Mismatch	149
Physiological	114
Power Failure	142
Rebreathing	131
specifications	186
SpO2 Sensor Failure/Disconnection	154
SpO2 Signal Inadequacy	155
SpO2/CO2/Remote Start/Stop Failure	153
Ambient Pressure Compensation Lost alarm	161
Ambient Temperature Compensation Lost alarm	162
Apnea alarm	129
Artificial nose	15, 18
Assisted Pressure Controlled Ventilation definition	85
Assisted Pressure Controlled Ventilation with Target Volume definition	85
Assisted Volume Controlled Ventilation definition	87
Audible range operator's position	113
Audience, Vivo Operating manual	6
Audio pause and reset	113
Audio pause button	24
B	
Backup inspiratory time setting	67

Backup rate setting	75
Battery	
charge	93
Click-on	95
icons	94
internal	94
operating time	98
priority	93
storage	99
usage	92
Breath mode	83
Breath rate setting	63
C	
Cables	
inspect	40
Calibration	
CO2	107
Caution, icon	7
CE mark	
standards	203
Change patient	173
Charge	
Click-on battery	96
Charge batteries	93
Check before first use, Vivo	31
Check CO2 Adapter alarm	158
Circuit Resistance and Compliance Limits	194
Circuit Type/Insert Mismatch alarm	148
Circuit Type/Insert Mismatch alarm	148
Cleaning	
CO2 sensor	108
FiO2 sensor	103
insert	172
main unit	170
patient air filters	172
patient circuit	172
Cleaning and maintenance	
safety information	19
Cleaning Vivo	170
Click-on battery	95
charger	96
CO2 Adapter check alarm	158
CO2 Sensor	
usage	104

CO2 sensor	
clean	108
connect	106
safety information	104
specifications	195
CO2 Sensor Accuracy Unspecified alarm	157
CO2 Sensor Error alarm	159
CO2 Sensor Failure/Disconnection alarm	156
CO2 sensor port	
position	26
CO2 zeroing	107
Compliance of standards	203
Connect	
click-on battery	95
CO2 sensor to Vivo	106
dual limb circuit	38
exhalation valve circuit (single limb)	39
FiO2 sensor to Vivo	102
insert to Vivo	35
leakage circuit (single limb)	39
nurse call	101
patient circuit	35
Vivo to AC power	34
Continuous Positive Airway Pressure	
definition	89
Contraindications, Vivo	5
CPAP	
definition	89
setting	81
D	
Data	
transfer between Vivo and PC	91
transfer with memory card	91
Data Parameters	181
Date format	53
DC power	
Click-on Battery LED	24
External DC	99
External DC LED	24
Internal Battery LED	24
Delivery settings	203
Device information	53
Device memory	52
Device settings	52
Dimensions	
specification	195
Disconnect insert	38
Disconnection alarm	130

Display	
navigate	45
overview	49
symbols	47
Display light	53
Disposal	175
Dual limb circuit	
connect	38
pneumatic diagram	176, 178
Dual limb insert	
position	26
E	
Electrical safety	
user precautions	11
End-tidal carbon dioxide	59
Enter	
operating mode	43
Environmental conditions	
safety information	12
specifications	193
Equipment designation and safety label	28
EtCO ₂	
High EtCO ₂ alarm	137
Low EtCO ₂ alarm	138
monitored value	59
surveillance, life-supporting treatment	9
Exhalation valve	
connect dual limb circuit	38
connect single limb circuit	39
Exhalation valve circuit (single limb)	
pneumatic diagram	176
Exhalation Valve Control Error alarm	150
Exhalation valve control pressure outlet	
position	27
Expiratory trigger	
setting	72
Expired minute volume, MVe	
monitored value	55
Expired tidal volume, V _{te}	
monitored value	56
External DC	99
inlet position	26
F	
FAA	214
Filter	
disposable	23
washable	23
Filtering/smoothing techniques	
specifications	195

Filters	
clean and replace	172
safety information	17
FiO2	
concentration, contraindication	5
High FiO2 alarm	133
Low FiO2 alarm	134
monitored value	56
FiO2 Failure/Disconnection alarm	160
FiO2 sensor	
clean	103
connect	102
usage	102
FiO2 sensor port	
position	26
First use check, Vivo	31
Flow pattern	
setting	80
Form	
patient settings	213
Front panel, main unit	24
Function Failure alarm	167
Function/navigation buttons	24
G	
General user precautions	8
H	
Harmonized standards	203
HCH	15, 18
Heat and moisture exchanger	15, 18
High Breath Rate alarm	127
High EtCO2 alarm	137
High Expired Minute Volume alarm	124
High Expired Tidal Volume alarm	120
High FiO2 alarm	133
High InspCO2 alarm	139
High Inspired CO2 alarm	139
High Inspired Minute Volume alarm	123
High Inspired Tidal Volume alarm	119
High MVe alarm	124
High MVi alarm	123
High Patient Air Temperature alarm	143
High PEEP alarm	117
High Pressure alarm	114
High Pulse Rate alarm	140
High SpO2 alarm	135
High Vte alarm	120
High Vti alarm	119
HME	15, 18
Humidification	

safety information	18
Humidity Compensation Lost alarm	163
Hygroscopic condenser humidifier	15, 18
I	
Icon	
battery	94
Caution	7
Operating manual	7
Warning	7
Indications for use, Vivo	5
Information button	24
Insert	
clean	172
connect to Vivo	35
lock and unlock	38
position	26, 27
Insert type	35
InspCO ₂	
High InspCO ₂ alarm	139
monitored value	59
Inspect	
cables	40
placement	40
Vivo before use	40
Inspiratory pressure	60
Inspiratory time	
monitored value	58
setting	65
Inspiratory trigger	
setting	70
Inspired carbon dioxide	59
Inspired minute volume, MV _i	
monitored value	55
Inspired tidal volume, V _{ti}	
monitored value	55
Integrated exhalation valve	
connect dual limb circuit	38
Internal battery	94
Internal Function Failure alarm	167
Introduction, Vivo	3
L	
Label	28
Last power source	
alarm	145, 146, 147
Leakage	
monitored value	54
Leakage circuit (single limb)	
pneumatic diagram	177
Leakage port	

connect circuit	39
LED	
Click-on battery	24
External DC	24
Front panel	24
Internal battery	24
LED Failure alarm	164
Life-supporting treatment	9
Light intensity	53
Lock insert	38
Low Alarm Battery alarm	165, 166
Low Breath Rate alarm	128
Low EtCO ₂ alarm	138
Low Expired Minute Volume alarm	126
Low Expired Tidal Volume alarm	122
Low FiO ₂ alarm	134
Low Inspired Minute Volume alarm	125
Low Inspired Tidal Volume alarm	121
Low Last Power Source alarm	145, 146, 147
Low MVE alarm	126
Low MVi alarm	125
Low PEEP alarm	118
Low Pressure alarm	116
Low Pulse Rate alarm	141
Low SpO ₂ alarm	136
Low Vte alarm	122
Low Vti alarm	121
M	
Main components, Vivo	22
Main screen	49
Main unit	
clean	170
Maintenance	174
safety information	19
Max pressure	
setting	77
Maximum inspiratory time	
setting	74
Memory card	
data transfer	91
Memory card slot	
position	26
Menu	
navigate	45
symbols	47
Min pressure	
setting	78

Minimum inspiratory time	
setting	73
Minute volume, expired, MVe	
monitored value	55
Minute volume, inspired, MVi	
monitored value	55
Modes	
definitions	82
delivery settings	203
Monitor section	52
Monitored value	54
% in TgV	56
% Spont	57
EtCO2	59
FiO2	56
InspCO2	59
Inspiratory time	58
Leakage	54
MVe, Minute volume, expired	55
MVi, Minute volume, inspired	55
PEEP	54
Pmean	54
Ppeak	54
Pulse rate	58
Rise time	58
specifications	185
SpO2	58
Spont rate	57
Tidal volume, expired, Vte	56
Tidal volume, inspired, Vti	55
Total rate	56
Vte, Tidal volume, expired	56
Vti, Tidal volume, inspired	55
MVe, Minute volume, expired	
monitored value	55
MVi, Minute volume, inspired	
monitored value	55
N	
Navigate	
menu	45
Nurse call	
connect to Vivo	101
connection position	25
electrical safety	11
O	
Obstruction Alarm	132
On/Off	
switch	43
On/Off button	
position	26

Operating conditions	
specifications	194
Operating mode	82
enter	43
Operator's position	
audible range	113
Others section	52
Oxygen	
safety information	20
Oxygen inlet	
position	27
specification	194
Oxygen saturation	
monitored value	58
P	
Part numbers	
accessories	209
main components	23
Patient	
change	173
Patient air outlet	
position	27
Patient air temperature alarm	143
Patient circuit	35
Adult	35
clean	172
configuration	35
insert	35
Pediatric	35
safety information	14
Patient circuit type	35
Patient mode	35, 82
Patient Mode/Insert Mismatch	
alarm	149
Patient Mode/Insert Mismatch alarm	149
Patient operating time	52
Patient settings	
adjust	41
form	213
PC	
transfer data from Vivo	91
PCV	
definition	84
PCV(A)	
definition	85
PCV(A+TgV)	
definition	85
PCV(TgV)	
definition	85
PCV-SIMV	

definition	86
Pediatric	
circuit type	35
insert	35
Pediatric mode	82
PEEP	
monitored value	54
setting	61
Perform pre-use test	41
Physiological Alarms	114
Apnea	129
Disconnection	130
High Breath Rate	127
High EtCO ₂	137
High Expired Minute Volume	124
High Expired Tidal Volume	120
High FiO ₂	133
High InspCO ₂	139
High Inspired Minute Volume	123
High Inspired Tidal Volume	119
High PEEP	117
High Pressure	114
High Pulse Rate	140
High SpO ₂	135
Low Breath Rate	128
Low EtCO ₂	138
Low Expired Minute Volume	126
Low Expired Tidal Volume	122
Low FiO ₂	134
Low Inspired Minute Volume	125
Low Inspired Tidal Volume	121
Low PEEP	118
Low Pressure	116
Low Pulse Rate	141
Low SpO ₂	136
Rebreathing	131
Placement	
inspect	40
Vivo	32
Pmean	
monitored value	54
Pneumatic diagram	
Dual limb circuit	176, 178
Exhalation valve circuit (single limb)	176
Leakage circuit (single limb)	177
Single limb circuit	179
Position	
operator, audible range	113
Power Failure alarm	142
Power source	

priority	93
Power supply	
specifications	192
Ppeak	
monitored value	54
Prepare for use, Vivo	31
Pressure Compensation Lost alarm	161
Pressure Controlled Ventilation	
definition	84
Pressure Controlled Ventilation with Synchronized Intermittent Mandatory Ventilation	
definition	86
Pressure Controlled Ventilation with Target Volume	
definition	85
Pressure Support Ventilation	
definition	83
Pressure Support Ventilation with Target Volume	
definition	84
Pre-use test	
perform	41
Priority	
power source	93
Product description, Vivo	22
Product label	28
Profiles	
delivery settings	203
Protective cover	
usage	110
PSV	
definition	83
PSV(TgV)	
definition	84
Pulse rate	
High Pulse Rate alarm	140
Low Pulse Rate alarm	141
monitored value	58
R	
Rebreathing alarm	131
Regular maintenance	174
Remote alarm	
usage	103
Remote Start/Stop	
connection position	26
Remote Start/Stop Failure alarm	153
Repair	174
Replace	
patient air filters	172
Reset	
alarm	113
Rise time	

monitored value	58
setting	69
S	
Safety Information	8
Safety information	
cleaning and maintenance	19
CO2 sensor	104
Environmental conditions	12
filters	17
humidification	18
oxygen	20
patient circuit	14
Safety label	28
Screen	
Alarm	51
Alarm/Event History	51
Main	49
Monitor	52
Others	52
Setup	50
Section	
Alarm	51
Monitor	52
Others	52
Setup	50
Serial number	53
Service	174
Setting	60
Backup inspiratory time	67
Backup rate	75
Breath rate	63
CPAP	81
Expiratory trigger	72
Flow pattern	80
Inspiratory time	65
Inspiratory trigger	70
Max pressure	77
Maximum inspiratory time	74
Min pressure	78
Minimum inspiratory time	73
PEEP	61
Rise time	69
Sigh	68
SIMV rate	64
SIMV Support pressure	71
Target volume	76
Tidal volume	79
setting	60
Settings	
at delivery	203
form	213

specifications	181
Setup section	50
Side panel, Vivo	25
Sigh	
definition	89
setting	68
SIMV	88
SIMV cycle	88
SIMV rate	88
setting	64
SIMV Support pressure	
setting	71
Single limb circuit	
pneumatic diagram	179
Single limb insert	
position	27
Sound level	
specification	194
Specifications	
alarms	186
CO2 sensor	195
dimensions	195
Environmental conditions	193
Filtering/smoothing techniques	195
miscellaneous	194
monitored values	185
operating conditions	194
oxygen inlet	194
power supply	192
settings	181
sound level	194
SpO2	
High SpO2 alarm	135
Low SpO2 alarm	136
monitored value	58
SpO2 sensor	
usage	108
SpO2 Sensor Failure/Disconnection alarm	154
SpO2 sensor port	
position	26
SpO2 Signal Inadequacy alarm	155
SpO2/CO2/Remote Start/Stop Failure alarm	153
Spont rate	
monitored value	57
Spontaneous breaths, %	57
Standard compliance	203
Standby mode	82
Start	
operating mode	43

treatment	43
Start/Stop button	24
Stop	
treatment	44
Vivo Stop	
treatment	44
Storage	174
battery	99
Switch off Vivo	44
Switch On/Off	43
Symbol	
Caution	7
Warning	7
Symbols	
Equipment designation and safety label	28
menu	47
Operating manual	7
Symbols Explanation	28
T	
Target volume	
in PCV, definition	85
in PSV, definition	84
setting	76
Target volume, in PCV + A, definition	85
Technical Alarms	142
Ambient Pressure Compensation Lost	161
Ambient Temperature Compensation Lost	162
Check CO2 Adapter	158
Circuit Type/Insert Mismatch	148
CO2 Sensor Accuracy Unspecified	157
CO2 Sensor Error	159
CO2 Sensor Failure/Disconnection	156
Critical Low Last Power Alarm	147
Exhalation Valve Control Error	150
FiO2 Failure/Disconnection	160
High Patient Air Temperature	143
Humidity Compensation Lost	163
Internal Function Failure	167
LED Failure	164
Low Alarm Battery	165, 166
Low Last Power Source	145, 146, 147
Patient Mode/Insert Mismatch	149
Power Failure	142
SpO2 Sensor Failure/Disconnection	154
SpO2 Signal Inadequacy	155
SpO2/CO2/Remote Start/Stop Failure	153
Vte/MVe Accuracy Unspecified	151
Vte/MVe Sensor Error	152
Technical specifications	176
Temperature alarm	143
Temperature Compensation Lost alarm	162

Test	
alarm	132
Tidal volume	
setting	79
Tidal volume, expired, Vte	
monitored value	56
Tidal volume, inspired, Vti	
monitored value	55
Time format	53
Total rate	
monitored value	56
Transfer data	
between Vivo and PC	91
with memory card	91
Treatment	
start	43
stop	44
Trolley	109
U	
Undesirable side effects, Vivo	5
Unlock insert	38
Up/down buttons	24
USB data connection port	
position	25
User interface	
navigate	45
symbols	47
User precautions	
electrical safety	11
environmental conditions	12
general	8
patient circuit	14
V	
VCV	
definition	87
VCV(A)	
definition	87
VCV-SIMV	
definition	88
Ventilation mode	83
Volume Controlled Ventilation	
definition	87
Volume Controlled Ventilation with Synchronized Intermittent Mandatory Ventilation	
definition	88
Vte, tidal volume, expired	
monitored value	56
Vti, tidal volume, inspired	
monitored value	55

W

Warning, icon 7
Water trap 18
Weight, Vivo 195